

MAINTENANCE AND OPERATION
INSTRUCTION MANUAL

DB9410-TX

Professional MPX over IP Encoder
with MicroMPX



Contents

| | |
|---|-----------|
| Introduction | 6 |
| Typographic conventions | 7 |
| General Information | 8 |
| <i>Product Features</i> | 9 |
| <i>Technical Specifications</i> | 9 |
| Panel Indicators and Appointments | 11 |
| <i>Front Panel</i> | 11 |
| <i>Rear Panel</i> | 12 |
| <i>The Pinout of an AES192 Connector</i> | 13 |
| <i>Pin Assignment</i> | 13 |
| <i>Connection</i> | 13 |
| <i>The Pinout of a DB15 HD GPIO / GPS Connector</i> | 14 |
| <i>GPI Example Connections</i> | 15 |
| <i>GPO Example Connections</i> | 16 |
| <i>Internal Connections of the GPIO Port</i> | 17 |
| Block diagram | 18 |
| Safety Warning | 19 |
| Operating Recommendations | 20 |
| Unpacking and inspection | 21 |
| Mounting | 21 |
| <i>Rack Requirements IU</i> | 21 |
| <i>Rack Requirements Compact Units</i> | 21 |
| <i>Stand-Alone Devices</i> | 21 |
| Overview | 22 |
| Getting Started | 23 |
| <i>Connection</i> | 23 |
| <i>Network Settings</i> | 23 |
| <i>Network Security Recommendations</i> | 23 |
| <i>LAN Port</i> | 23 |
| Network Discovery | 24 |
| <i>DEVA Ethernet Setup Tool</i> | 24 |
| <i>Download latest version</i> | 24 |
| <i>Using the tool</i> | 24 |
| About the MicroMPX Codec | 27 |
| <i>A Distinction from L/R signals</i> | 27 |
| Use Cases & Applications | 28 |
| <i>Simple STL: Use with Any FM Processor</i> | 28 |
| <i>One Processor to Many Transmitters</i> | 29 |
| <i>Use with private networks and IP Radios</i> | 30 |
| <i>Redundant Paths and Backup Scenarios</i> | 31 |
| <i>Single Encoder & Decoder, Dual Networks</i> | 31 |
| <i>Dual Encoder, Single Decoder</i> | 32 |
| <i>Dual Encoder, Dual Decoder</i> | 33 |
| <i>SFN + GPS</i> | 34 |
| Technical Notes | 35 |
| <i>MicroMPX Codec Setup Tips and Best Practices</i> | 35 |
| <i>Packet Jitter</i> | 35 |
| <i>Packet Loss</i> | 35 |

| | |
|---|-----------|
| <i>Firewall and Security</i> | 35 |
| <i>Tilt Correction</i> | 36 |
| <i>Cooling</i> | 36 |
| WEB Interface | 37 |
| <i>Access</i> | 37 |
| <i>Input</i> | 38 |
| <i>Stream</i> | 39 |
| <i>Unicast vs. Multicast</i> | 40 |
| <i>Configuring Streams</i> | 40 |
| <i>DSCP & TTL Settings (Multicast Only)</i> | 40 |
| <i>DSCP (Differentiated Services Code Point)</i> | 40 |
| <i>TTL (Time To Live)</i> | 40 |
| <i>MicroMPX Encoder Settings</i> | 41 |
| <i>Enabling the Encoder</i> | 41 |
| <i>MPX Input Level</i> | 41 |
| <i>Clip Indicator</i> | 41 |
| <i>Bitrate</i> | 41 |
| <i>Additional Notes on Bandwidth</i> | 42 |
| <i>RIST support</i> | 43 |
| <i>MicroMPX+ for bitrates down to 176 kbit/s</i> | 44 |
| <i>MicroMPX+ Variable Bitrate for even lower bitrates</i> | 44 |
| <i>MicroMPX Encoder configuration</i> | 45 |
| <i>Forward error correction</i> | 45 |
| <i>Redundant links</i> | 46 |
| <i>Multiple decoders</i> | 46 |
| <i>Port forwarding and networks</i> | 46 |
| <i>Security / Password protection</i> | 48 |
| <i>GPS synchronization</i> | 49 |
| <i>Encoder</i> | 49 |
| <i>Connecting a third party GPS receiver</i> | 50 |
| <i>Encoder Dashboard</i> | 53 |
| <i>Stream Error Correction</i> | 53 |
| <i>Delay Size and Overhead</i> | 53 |
| <i>Calculating Bandwidth Usage</i> | 53 |
| <i>When to Use Error Correction</i> | 54 |
| <i>Stream Display – Things to Note</i> | 54 |
| <i>Grey Horizontal Line</i> | 54 |
| <i>Green Line (Incoming Stream)</i> | 54 |
| <i>White Vertical Marks (Keyframes)</i> | 54 |
| <i>Blue Vertical Lines (Error Correction Packets)</i> | 54 |
| <i>Red Vertical Lines (Packet Loss / Errors)</i> | 54 |
| <i>Keyframe Interval</i> | 55 |
| <i>Error Correction Size (Delay Size)</i> | 55 |
| <i>Error Correction Overhead</i> | 55 |
| <i>Understanding Size vs. Overhead Trade-Offs</i> | 56 |
| <i>Rate Limiter (On / Off)</i> | 56 |
| <i>Limit Rate Below</i> | 56 |

| | |
|---|-----------|
| <i>User accounts</i> | 58 |
| <i>as Administrator</i> | 58 |
| <i>as User</i> | 58 |
| <i>System</i> | 59 |
| <i>Account</i> | 59 |
| APPENDIX A - Possible problems and solutions | 60 |
| <i>Peak control is not perfect</i> | 60 |
| APPENDIX B - RIST URL Syntax and Examples | 61 |
| <i>URL Help output</i> | 61 |
| <i>Simple, Main and Advanced Profiles</i> | 61 |
| <i>Main and Advanced Profiles</i> | 61 |
| <i>Advanced Profile</i> | 61 |
| <i>Additional Explanations</i> | 62 |
| <i>Examples</i> | 64 |
| APPENDIX C - Recovery mode | 65 |
| <i>How to enter Recovery mode?</i> | 65 |
| <i>Firmware update</i> | 66 |
| <i>LOGs</i> | 68 |
| <i>Recovery menu</i> | 68 |
| WARRANTY TERMS AND CONDITIONS | 69 |
| Product Registration Card | 70 |

THIS PAGE
IS INTENTIONALLY
LEFT BLANK

Introduction

DEVA Broadcast Ltd. is an international communications and high-technology manufacturing organization, its corporate headquarters and facility located in Burgas, Bulgaria. The company serves the broadcast and corporate markets worldwide – from consumers and small businesses to the largest global organizations. It is dedicated to the research, design, development and provision of advanced products, systems and services. DEVA Broadcast launched its own brand back in 1997 and has nowadays evolved to become known as a market leader and internationally reputed manufacturer of user-friendly, cost-effective and innovative broadcast products.

Creativity and innovation are deeply woven into DEVA Broadcast corporate culture. Through successful engineering, marketing and management our team of dedicated professionals creates future-oriented solutions to improve customers' performance. You may rely that all issues communicated to our crew would be addressed accordingly. We pride ourselves on our pre and post-sales support and purchase services, which along with the outstanding quality of our radio gear have won us due respect and the market authority position.

DEVA Broadcast best-of-breed solutions have become the best sellers for our partners. The strategic partnerships which have been formed with industry leaders during all these years that we have been operating on the broadcasting market, have proved us a reliable business partner and a valuable asset, as our dealers worldwide would confirm. In constant pursuit of precision and long-term satisfaction, DEVA Broadcast enhances the reputation of our partners and clients alike. Furthermore, we have already a proven merit as a credible partner provider.

Our portfolio offers complete line of high quality and competitive products for FM and Digital Radio, Radio Networks, Telecommunication Operators and regulation authorities. For almost two decades of intensive software and hardware development, we have achieved a unique price-performance and endurance of our product lines. Our company's multitude of equipment and services is in line with the latest technologies and key trends. The most recognizable characteristics attributed to DEVA Broadcast products are their clear-cut, streamlined design, easiness of use and cost-effectiveness: simplicity of forms but multiplicity of functions.

For us there is no stage when we deem that we have reached the most satisfactory level in our work. Our engineers are in constant pursuit of new ideas and technologies to be captured in DEVA Broadcast solutions. Simultaneously, a strict control is being exercised at each step of any new development. Experience and hard work are our fundament but the continuous improving process is what we never leave aside. DEVA Broadcast participates on a regular basis in all landmark broadcasting events, not only to promote its products, but to exchange valuable know-how and experience. We are also engaged in international large-scale projects involving radio and audio solutions which makes us even more competitive on the global market.

All DEVA Broadcast products are developed and produced in accordance with the latest ISO 9001 quality control standards.

Typographic conventions

The following table describes important conventions used in the manual.

| Convention and Style | Description | Examples |
|---|--|--|
| <i>Menu > Sub Menu > Menu Command</i> | A menu item(s) and menu command that you need to click in sequence | Click <i>Settings > General</i> |
| [Button] | Interface Interactive buttons | Press [OK] to save the changes |
| NOTE | Important notes and recommendations | NOTE: The notification will appear only once |
| <u>“Reference Name” on Page XXX</u> | References and links | refer to <u>“New Connection”</u> (see <u>“Monitoring” on page 56</u>) |
| Example | Used when example text is cited | Example for E-mail Notification: Date: 04 Nov 2013, 07:31:11 |

General Information

The DB9410-TX is a high-performance, MPX over IP Encoder tailored to meet the modern demands of broadcast audio transmission. At its core is the innovative MicroMPX (μ MPX) algorithm developed by Thimeo, a purpose-built codec specifically designed for FM MPX transport. This technology ensures efficient use of network bandwidth, down to as little as 320 kbps while preserving excellent audio quality and maintaining full stereo and RDS integrity. The DB9410-TX enables robust, low-latency streaming over public or private IP networks, making it an ideal solution for both regional and nationwide broadcasting scenarios.

Despite its streamlined design, the DB9410-TX integrates effortlessly into existing setups. LED indicators on the front panel offer immediate insight into operational status, while configuration and monitoring are made simple through DEVA's intuitive HTML5-based web interface. This web control panel is accessible via any modern browser on PC, tablet, or smartphone, ensuring flexible management whether locally or from remote locations.

As part of DEVA's growing portfolio of IP audio solutions, the DB9410-TX is engineered with precision and built using top-tier components, including high-grade ADCs for maximum signal fidelity. It supports both Analog MPX and Digital AES192 inputs, ensuring broad compatibility across different transmitter systems and network architectures. Whether deployed for a single transmitter site or integrated into a larger network, the DB9410-TX delivers consistent, high-quality audio over IP.

Combining DEVA's proven reliability with cutting-edge MicroMPX technology, the DB9410-TX offers broadcasters a cost-effective, future-ready encoder that meets the demands of modern FM transmission. It is the perfect choice for professionals seeking dependable, bandwidth-efficient MPX distribution without compromising audio performance.

By choosing DEVA's DB9410-TX, broadcasters benefit from the company's tradition of innovation, quality, and support—hallmarks that continue to define DEVA's role as a leader in broadcast technology.

PRODUCT FEATURES

- High quality FM MPX encoding function
- High end ADC converter for optimal quality
- Ultra low latency, all-digital DSP based design
- Remotely upgradable firmware to ensure improved operation
- Headphone audio output
- Very Intuitive Embedded WEB server for interactive supervision
- Full online remote control of all parameters via IP
- Configuration via web user interface for easy setup
- Optional Redundant 230V or 48V (DC) power supply
- Forward Error Correction to reduce bit errors in data stream
- USB flash drive for Audio Backup Storage
- Apple and Android devices support
- SNTP for automatic synchronization of the built-in clock
- Protected access to the device settings
- LAN port for full TCP/IP remote control and monitoring
- Attractive price and very good price-performance ratio
- Proved and reliable hardware for 24/7/365 operating
- 1U Rack mountable Aluminum Case for high RF immunity
- Easy Installation and Setup

TECHNICAL SPECIFICATIONS

| AUDIO ENCODER | |
|---------------------------------|---|
| Codec | μMPX or raw PCM |
| Sample rates | 192 kHz and 216 kHz, 24 bits |
| Signal Processing | 24 Bit AD/DA conversion |
| PCM | |
| Bit depth | 12 - 16, 20, 24 bit |
| FEC | RIST, ProMPEG FEC #3, release 2 |
| Bandwidth | 2.4 - 4.6 Mbps (no FEC) |
| μMPX | |
| Bitrates | 320, 384, 448, 576, 800 kbit/s |
| FEC | μMPX FEC, RIST, Pro-MPEG FEC #3 release 2 |
| Bandwidth | 320 - 800 kbps (no FEC) |
| ANALOG MPX INPUT | |
| Connector | BNC |
| Type | Unbalanced |
| Level | +14 dBu (max. +16 dBu) |
| Sample rate | 192 kHz and 216 kHz, 24 bits |
| Dynamic range | 121 dB |
| DIGITAL MPX AES192 INPUT | |
| Connector | RJ-45, balanced, EMI suppressed |
| Standard | AES3 |
| Sampling Rate | up to 192kHz, 24 bits |

| GPS PORT | |
|--|---|
| Connector | DB15, Male |
| Protocol | NMEA 0183, 9600bps |
| Sync | 1 PPS, Square Wave, TTL Compatible |
| FRONT PANEL | |
| Status Indicators | 4 LEDs |
| Headphones | 1/8" (3.5mm) phones jack |
| USB | Type A for Backup audio player |
| USER INTERFACE | |
| Web interface | Full control and Status information |
| NETWORK | |
| Connector | RJ-45 |
| Type | Ethernet, 1000Mbps |
| Device discovery | UPnP support |
| OPERATING CONDITIONS | |
| Temperature | -15°C to 55°C |
| Humidity | < 95%, non-condensing |
| Altitude | 0 to 5000m above sea level |
| POWER | |
| Voltage | 100-240V / 50-60 Hz |
| Power Consumption | 12VA |
| Connector | IEC320, Fused and EMI-suppressed |
| OPTIONAL REDUNDANT POWER SUPPLY | |
| Option 1: 220V AC | 90 - 260V AC (nominal 100 - 240V AC) 47 - 63 Hz (nominal 50 - 60 Hz) |
| Option 2: 48V DC | 36 - 72V DC (nominal 48V DC) |
| SIZE AND WEIGHT | |
| Dimensions (W;H;D) | 485 x 44 x 180 mm |
| Shipping Weight | 540 x 115 x 300 mm / 2.673 kg |

Panel Indicators and Appointments

FRONT PANEL



1. Phones Output
2. Power LED Indicator
3. LAN LED Indicator
4. Memory LED indicator
5. LINK LED indicator
6. USB port

REAR PANEL



1. LAN Port / Internet Input – standard RJ-45 port
2. GPIO / GPS Port – DB15 HD, Male
3. AES 192 – RJ-45, Digital MPX Output
4. MPX – BNC, Analog MPX Output
5. Factory Defaults Reset button
6. Redundant Power Supply – 48V DC
7. Redundant Power Supply – 100-240V AC / 50-60 Hz
8. Mains connector – 110-240VAC / 50-60 Hz, IEC-320 C14 type
9. GND

THE PINOUT OF AN AES192 CONNECTOR

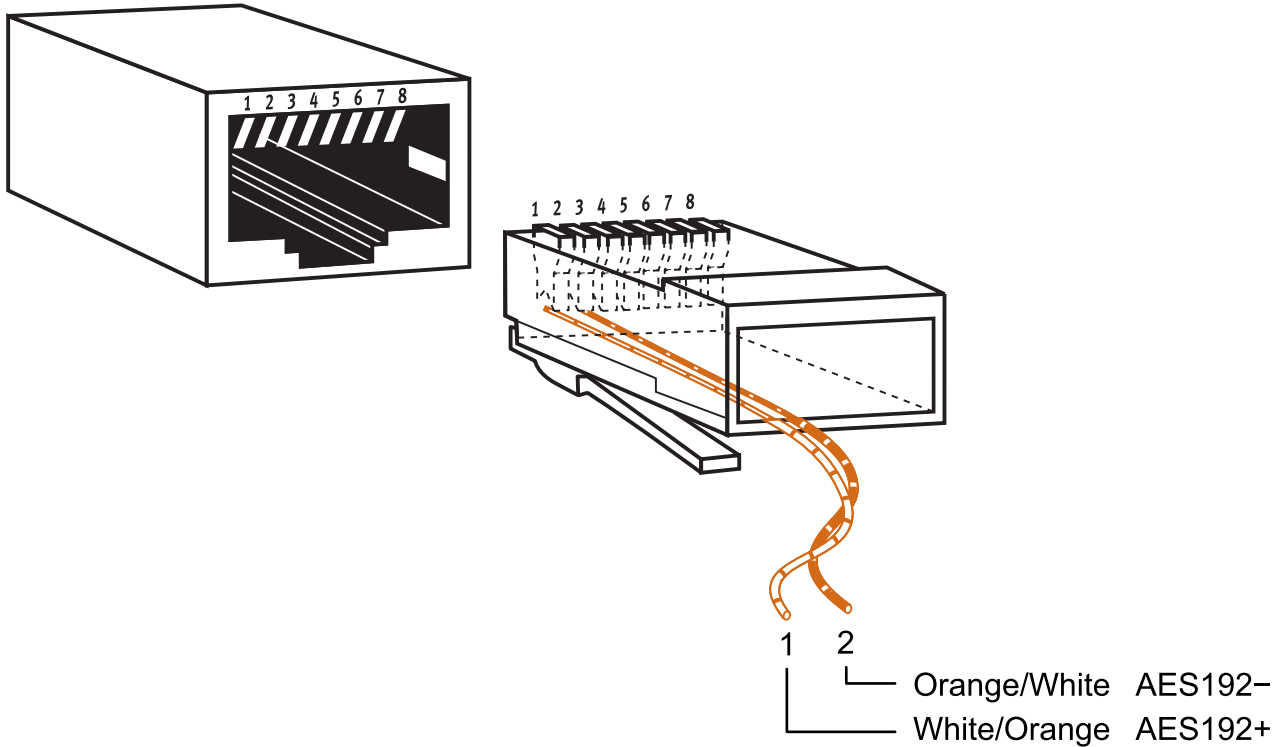

Pin Assignment

- Pin 1: White/Orange – AES192+
- Pin 2: Orange/White – AES192-

Connection

Any StudioHub cable or self-made audio cable may be used to connect to the DB9410 AES192 port. Although AES192 operates at a 192 kHz sample rate with 24-bit resolution, the signal can be distributed reliably over standard Cat-5 or Cat-6 structured cabling infrastructure.

The Digital MPX signal is transmitted as a differential signal on pins 1 and 2 (AES192+ and AES192-).

THE PINOUT OF A DB15 HD GPIO / GPS CONNECTOR

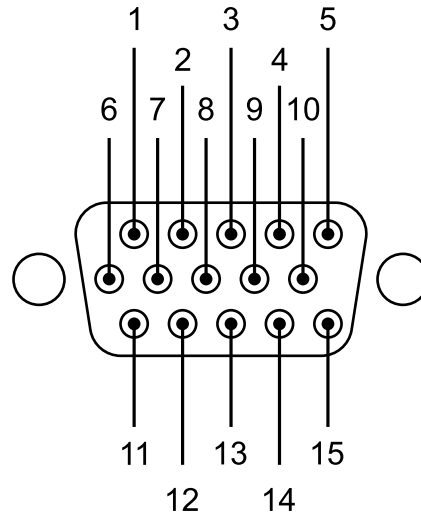

DB15 HD, Male

| Pin | Function | Direction |
|-----|----------|----------------------------------|
| 1 | GPI2 | Opto isolated Input |
| 2 | GPS RX | GPS Communication Output |
| 3 | 5V GPS | GPS +5V, Fuse protected (0.5A) |
| 4 | GPO3 | Solid State Relay |
| 5 | GPO1 | Solid State Relay |
| 6 | GPI3 | Opto isolated Input |
| 7 | GPI1 | Opto isolated Input |
| 8 | GPS TX | GPS Communication Input |
| 9 | PPS IN | GPS PPS (Pulse Per Second) Input |
| 10 | GPO2 | Solid State Relay |
| 11 | GPICOM | Common GPO rail |
| 12 | GP5V | +5V (Out), Fuse protected (0.5A) |
| 13 | GPS GND | GPS Ground |
| 14 | GPGND | GPIO Ground |
| 15 | GPOCOM | Common GPO rail |

GPI EXAMPLE CONNECTIONS

To activate one Input, GPI pin would be pulled to ground , with a voltage applied on the GPICOM pin (Common to all GPI).

Using external power supply is the recommended method in order to avoid possible ground loops between equipment, as shown in Figure 1-1. The maximum allowed external power supply for logic control is 48 volts DC.

NOTE the presence of Current Limiting Resistors per GPI pin. The intention is to limit the current to 20mA for each GPI pin. Use the table below to choose the suitable Resistor's value.

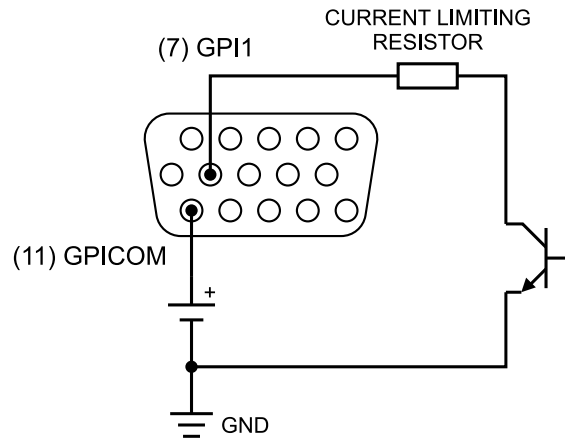

Figure 1-1 - External Power Supply

If the equipment being controlled is electrically isolated, then the use of the GPIO port's power supply is acceptable. The easiest way is shown on Figure 1-2.

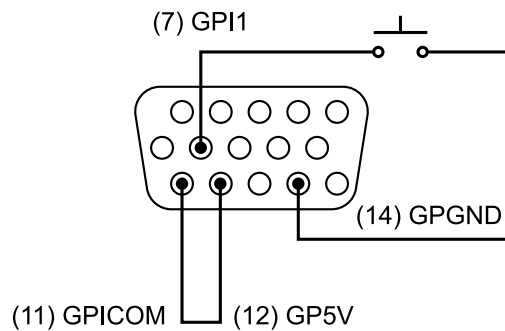

Figure 1-2 - GPIO Port's Power Supply

CAUTION: The use of current limiting resistor per GPI pin is required for some voltages, see table (each input has an internal 330ohms protection).

NOT PROTECTING THE GPI COULD DAMAGE YOUR DEVICE.

| VDC | External Resistor |
|-----|-------------------|
| 5 | 0 |
| 6 | 0 |
| 12 | 680 / 0.25Watt |
| 24 | 1.8k / 0.5Watt |
| 48 | 3.9k / 1Watt |

GPO EXAMPLE CONNECTIONS

The GPO portion of the GPIO port are Solid State Relays. Current should be limited to 100 mA per GPO pin of a port. Maximum allowed voltage is 48 volts. The following diagram shows the recommended connections for outputs with the use of an external power supply.

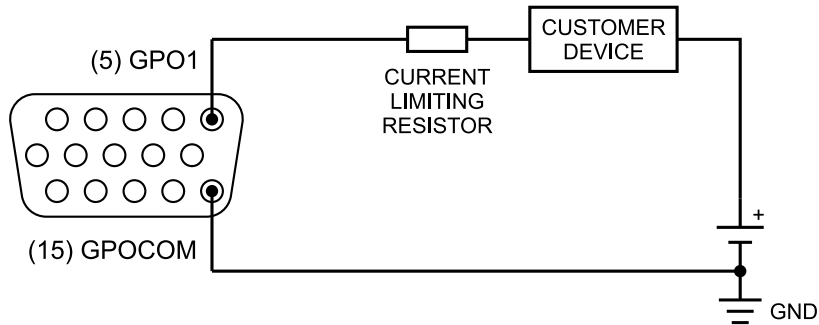

Figure 2-1 - External Power Supply

If necessary, a Current Limiting Resistors must be used to limit the current to 100mA for each GPO pin.

NOT PROTECTING THE GPO COULD DAMAGE YOUR DEVICE.

If the device being controlled is electrically isolated, than the internal GP5V supply can be used, maintaining a 100mA limit on current drawn.

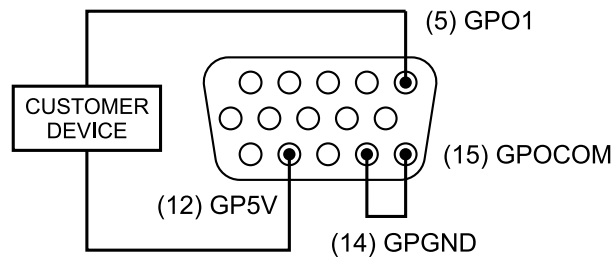

Figure 2-2 - GPIO Port's Power Supply

NOTE: GPO pins and GPOCOM are not polarized, current can flow both directions.

INTERNAL CONNECTIONS OF THE GPIO PORT

GPIO port provides 3 GPI (opto isolated inputs) and 3 GPO (solid state relays). Port is capable of driving a combined current of 100mA. Each GPI pin should be limited to 20mA of current.

Figure 3 shows a simplified diagram of the internal wiring behind the connector. The EMI Filters' parts are omitted for the sake of simplicity.

All of the inputs and all of the outputs on the GPIO port are grouped together. The 3 GPO outputs are on 3 separate output pins, but they share the same "Common Return" connection GPOCOM on pin 15. Similarly, the 3 GPI input pins share one high-side rail GPICOM, connected to pin 11.

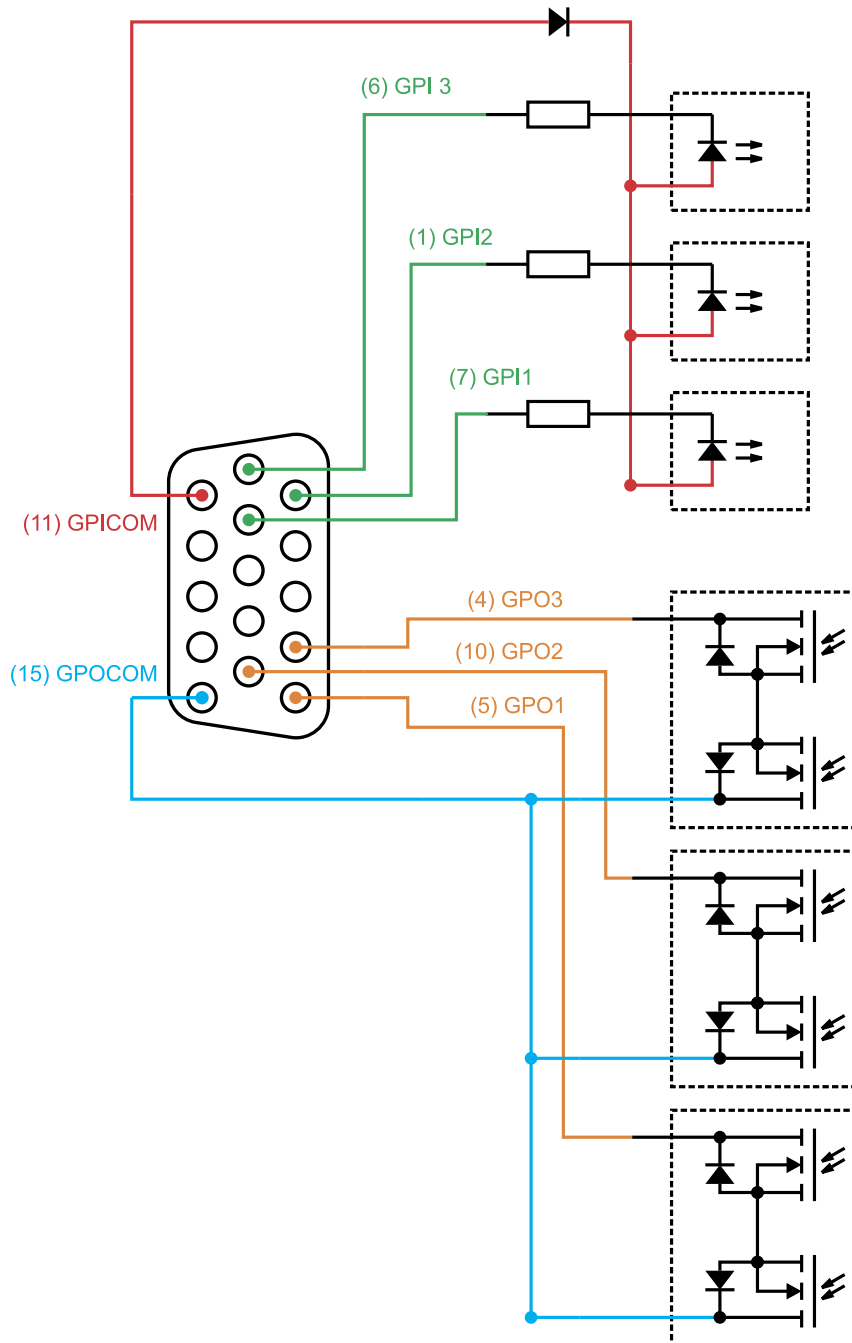
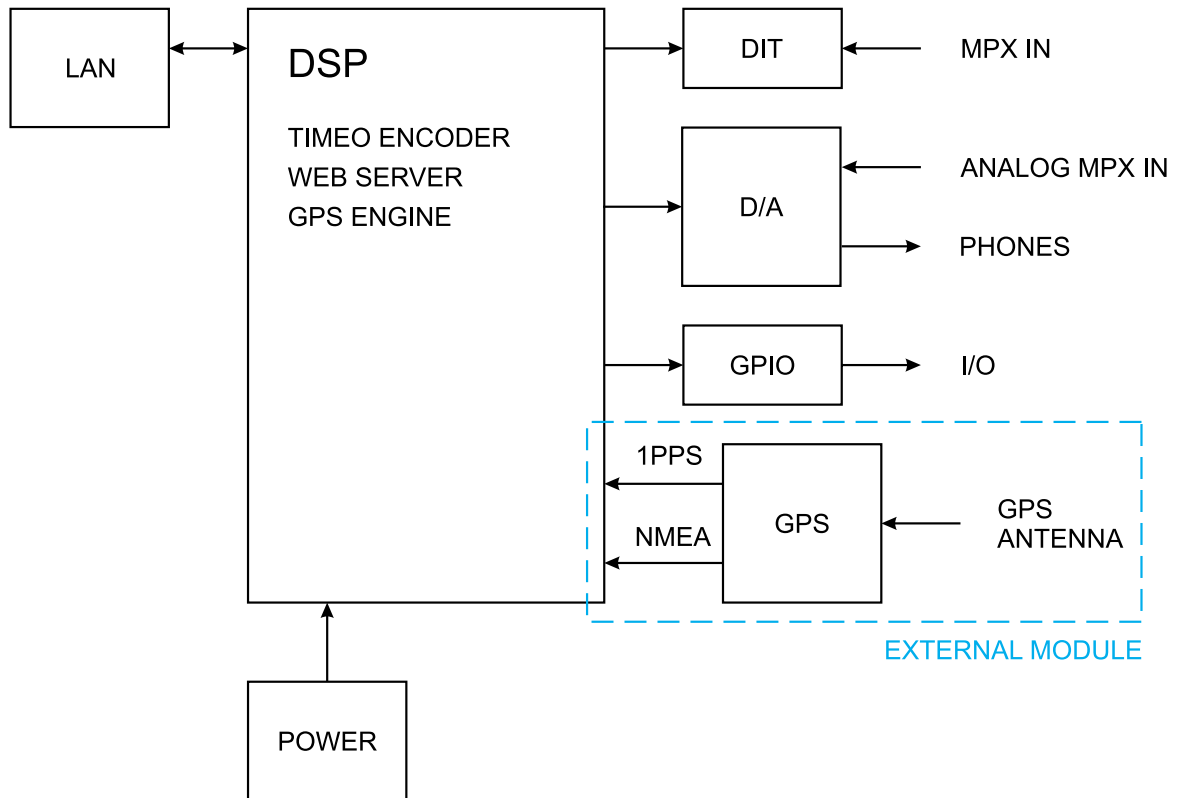

Figure 3

Block diagram

A simplified block diagram of DB9410-TX is shown below:



**NO USER-SERVICEABLE COMPONENTS INSIDE.
REFER ALL SERVICING TO QUALIFIED TECHNICAL PERSONNEL**

Safety Warning

ALWAYS OBSERVE THE SAFETY PRECAUTIONS.

Careful observance of the safety precautions will help prevent physical injury, damage of the equipment, and extend the equipment life.

- The servicing of electronic equipment should be performed only by qualified personnel;
- Before removing the covers the unit must be switched off and the mains cable unplugged;
- When the equipment is open, the power supply capacitors should be discharged using a suitable resistor;
- Never touch the wires or the electrical circuits;
- Use insulated tools only;
- Never touch the metal semiconductor. They might carry high voltages;
- For removing and installing electronic components, follow the recommendations for handling MOS components.
- Do not remove the factory sticker from the equipment. It contains information as regards the name, serial number and MAC address of the device.
- To join the equipment to the mains supply, use the power cord purchased with the equipment.

ATTENTION: The device has an internal Lithium battery. Do not try to re-charge this battery! In case the battery needs to be changed, please contact us for detailed instructions and information of the battery type.

Operating Recommendations

To ensure normal operation of the DEVA unit, we recommend following the instructions listed below.

- Install the unit in places with good air conditioning. The unit is designed to operate within the ambient temperature range of 10 to 50°C. The equipment rack should be ventilated in order for the device to keep its internal temperature below the maximum ambient temperatures;
- We do not recommend installation in rooms with high humidity, dusty places or other aggressive conditions;
- Although the device is intended to be installed closed to exciters or transmitters, we do recommend the device to be located away from abnormally high RF fields.
- Use only checked power supply cables. We strongly recommend the usage of shielded cables;
- Connect the DEVA unit to reliable power supply sources only. In case of unstable power supply, please use Uninterruptible Power Supply (UPS);
- Use the device only with its top cover on to avoid electromagnetic anomalies. Otherwise, this may cause problems with the normal functionality of the unit;
- To ensure normal remote operation of the unit, make sure to connect the device to a good quality Internet connection;
- For the normal operation of your DEVA device, check if the network settings past through all the required data traffic.

Unpacking and inspection

Upon receipt, the equipment should be inspected for possible shipping damages. If such are found or suspected, notify the carrier at once and contact DEVA Broadcast Ltd. The original shipping carton box and packing materials should be kept for possible reuse, in case of return for Warranty repair, for example. Shipping damages as a result of improper packing for return may invalidate the Warranty!

The packing material (plastic bags, polystyrene, nails, etc.) must never be left within reach of children, as these items are potential sources of danger.

IT IS VERY IMPORTANT that the [“Product Registration Card”](#) included in the Manual be completed accurately and returned. This will assure coverage of the terms of the Warranty and it will provide a means of trace in case of lost or stolen equipment. In addition, the user will automatically receive SERVICE OR MODIFICATION INSTRUCTIONS from DEVA Broadcast Ltd.

Mounting

RACK REQUIREMENTS 1U

The unit mounts in a standard 19-inch equipment rack and requires only 1 $\frac{3}{4}$ inches (1U) of vertical rack space. In order the painted finish around the mounting holes to be protected, the use of plastic washers is recommended.

RACK REQUIREMENTS COMPACT UNITS

Our customized 1U 19-inch rack accessory provides a professional mounting option for up to three compact size DEVA units. It is made of milled aluminum and finished in black powder coat. Two extra blanking panels and set of mounting screws are provided with each rack bracket kit.

STAND-ALONE DEVICES

DEVA's stand-alone units (Radio Explorer series, BandScanner series, DVB Explorer) do not require additional tools or installation brackets.

Overview

MicroMPX or μ MPX is a codec that transfers a full FM composite or MPX signal, meaning audio plus stereo pilot and RDS, over a low bitrate connection. It currently supports bitrates from 320 upto 800 kbit/s, and bitrates down to 176 kbit/s if you're using MicroMPX+ mode.

MicroMPX was developed specifically for use on FM, and even though the bitrates are low, it does not introduce typical lossy compression artifacts such as pre- and postringing or watery sounds. It also maintains peak control. If you use a composite clipper, the extra loudness that composite clipping generates also survives the MicroMPX codec. So for all relevant purposes, there's no real difference between connecting the direct composite output of a processor to the FM transmitter and connecting the MicroMPX decoder output to that same transmitter. (It is a lossy codec so the signal is not identical, which can become relevant when using a Single Frequency Network – more about that later.)

MicroMPX only needs one-way communication (from the encoder to the decoder, typically from the studio site to the transmitter site). This means that it can be sent over connections such as satellite links. It has several redundancy mechanisms to handle network or IP link problems: it can add recovery data to recover lost packets and send the same data over multiple connections so that as long as one of the connections works, the signal keeps playing. It is also possible to use multiple encoders that send their data to one decoder, to handle problems on the encoder end.

One encoder can feed any number of decoders (depending on the available bandwidth), and network multicasting or broadcasting is possible.

With MicroMPX, you can encode the full MPX signal in one location, and just spread it from there to all your transmitters, which will all get the same signal at the same time.

WARNING: Sending MicroMPX over an unreliable connection such as the public internet may work perfectly fine, but it can also cause dropouts. If possible, use a reliable connection, or redundant connections.

Getting Started

The DB9410 series are provided with preliminary settled μ MPX licenses.

In order for the normal operation of the DB9410-TX to be guaranteed, you will need fulfill the following conditions:

1. Standard Ethernet 10/100M connection;
2. Correctly assigned Network configuration and device settings.

To make sure that all the conditions are fulfilled please, follow the instructions below.

CONNECTION

1. Install the unit on its operation place;
2. Using the provided power cable, connect the unit to the power supply network;
3. Connect the antenna cable to the RF antenna input connector located on the rear panel of the device;
4. Connect the DB9410-TX to the TCP/IP network using direct network cable.

NETWORK SETTINGS

After connecting the network cable the Led 'LAN' located on the rear panel must be ON or flashing. The next and most important step for configuration is the adjustment procedure of the Network Communication. The settings shown below are Default Network Settings:

| | | | |
|----------------|------------------|------------------|------------------|
| DHCP | Enabled | Gateway | Assigned by DHCP |
| IP | Assigned by DHCP | DNS | Assigned by DHCP |
| Netmask | Assigned by DHCP | HTTP Port | 80 |

NETWORK SECURITY RECOMMENDATIONS

1. It is not recommended the DB9410-TX to be directly connected to the Internet. This may lead to unregulated access and/or problematic operation of the device. To ensure secure connection, we recommend the device to be installed behind a router with an active firewall.
2. If remote access to the device is needed, we recommend using VPN to the router or the port of the relevant service (WEB, SNMP, Application, etc.) to be properly NAT forwarded.
3. If NAT forward is used, it is highly recommended random ports of your choice to be used. Not the standard ones (80 for WEB, 161 for SNMP, etc.).
4. Using DMZ connection is not recommended.
5. Make sure to change the standard access credentials (usernames and passwords, SNMP communities).

For detailed information as regards the recommendations listed above or need of further instructions, please contact your network administrator.

LAN PORT

For normal operation it is necessary the device to be connected to a local network or Internet by cable with RJ-45 connector.

Network Discovery

DEVA ETHERNET SETUP TOOL

The DEVA Ethernet Setup Tool is designed to detect and configure networked DEVA products that lack front-panel IP configuration or UPnP support. It simplifies network setup by identifying the device's current IP address and allowing changes.

Once the device is connected to a local network or to the Internet by the applied LAN cable, download and install the DEVA Ethernet Setup Tool.

DOWNLOAD LATEST VERSION

The latest version of DEVA Ethernet Setup Software can be found on our website: <http://www.devabroadcast.com/downloads>

IMPORTANT: This software requires the installation of third-party software called WinPcap (<https://winpcap.org>) if it is not installed already.

USING THE TOOL

In order for the tool to be able to find the device during the network scan, please make sure that the unit is connected to the power supply chain and Ethernet network. Then, open the DEVA Ethernet Setup Tool and follow the instructions listed below:

1. Once the program window opens, an automatic network scan process will be started.

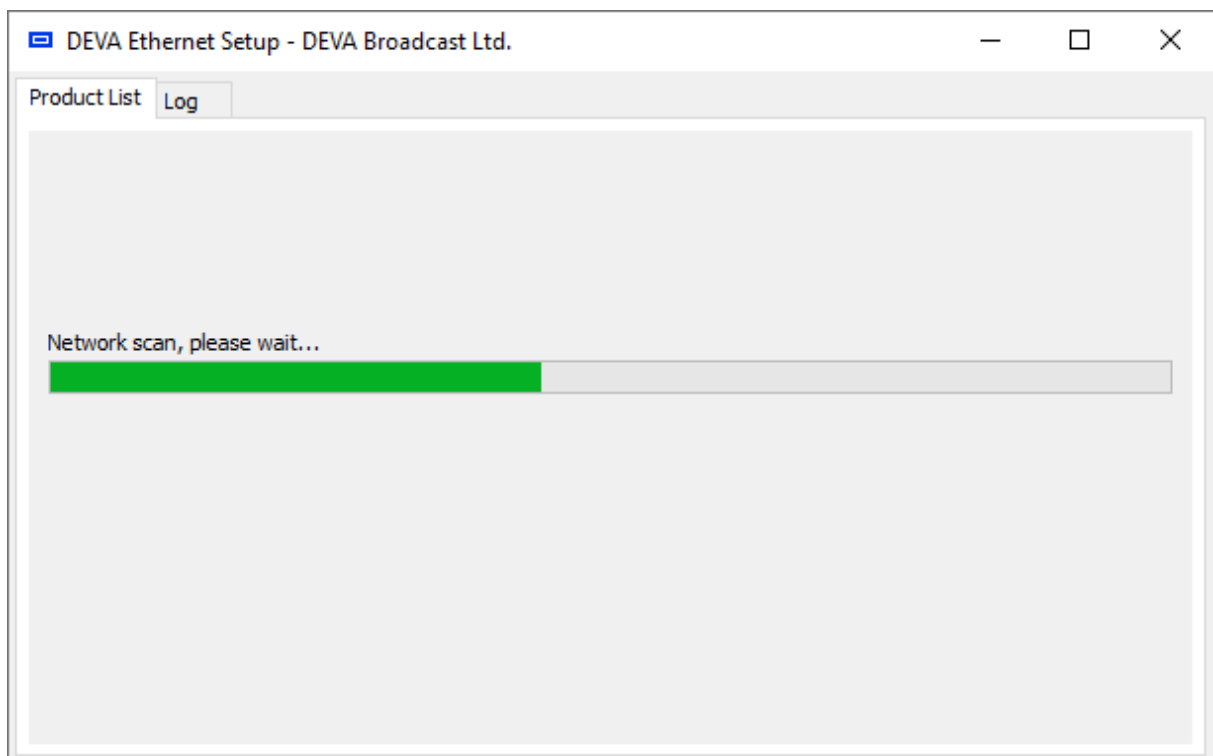

2. Once the network scanning process is completed, the collected data will be depicted in section Product List:

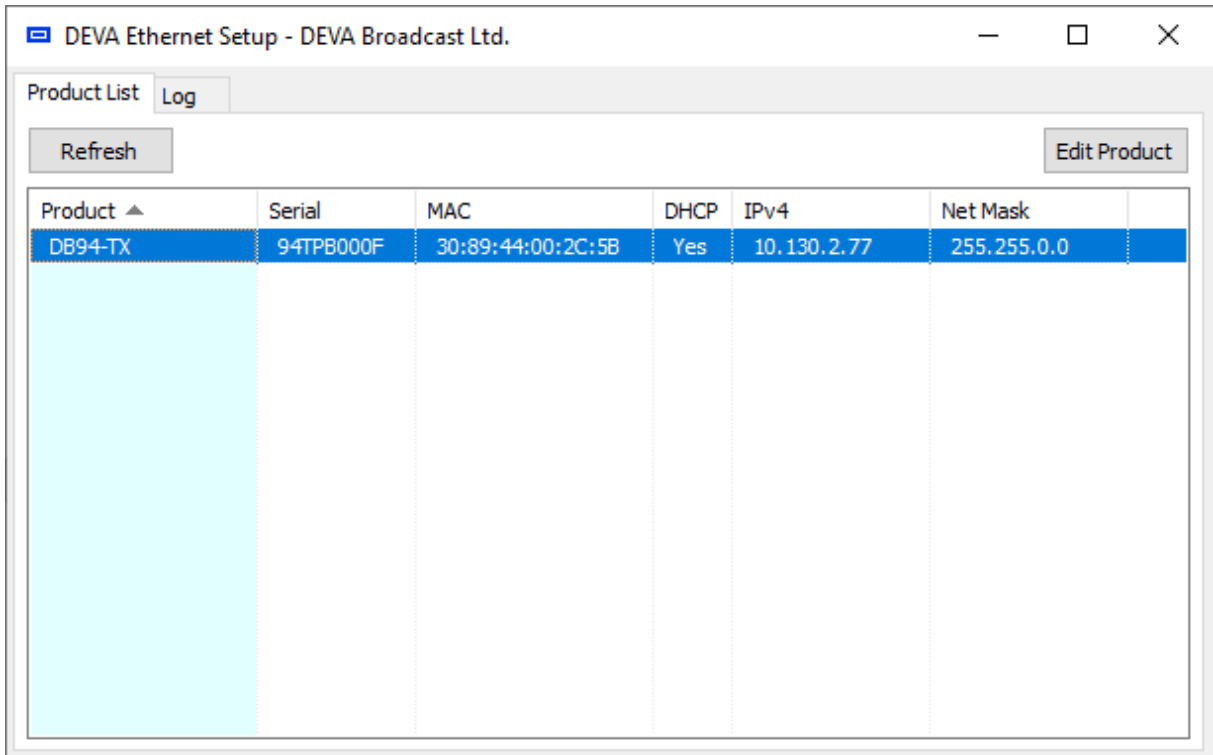

3. To change the parameters, select the product and press [Edit Product]. A new window will appear:

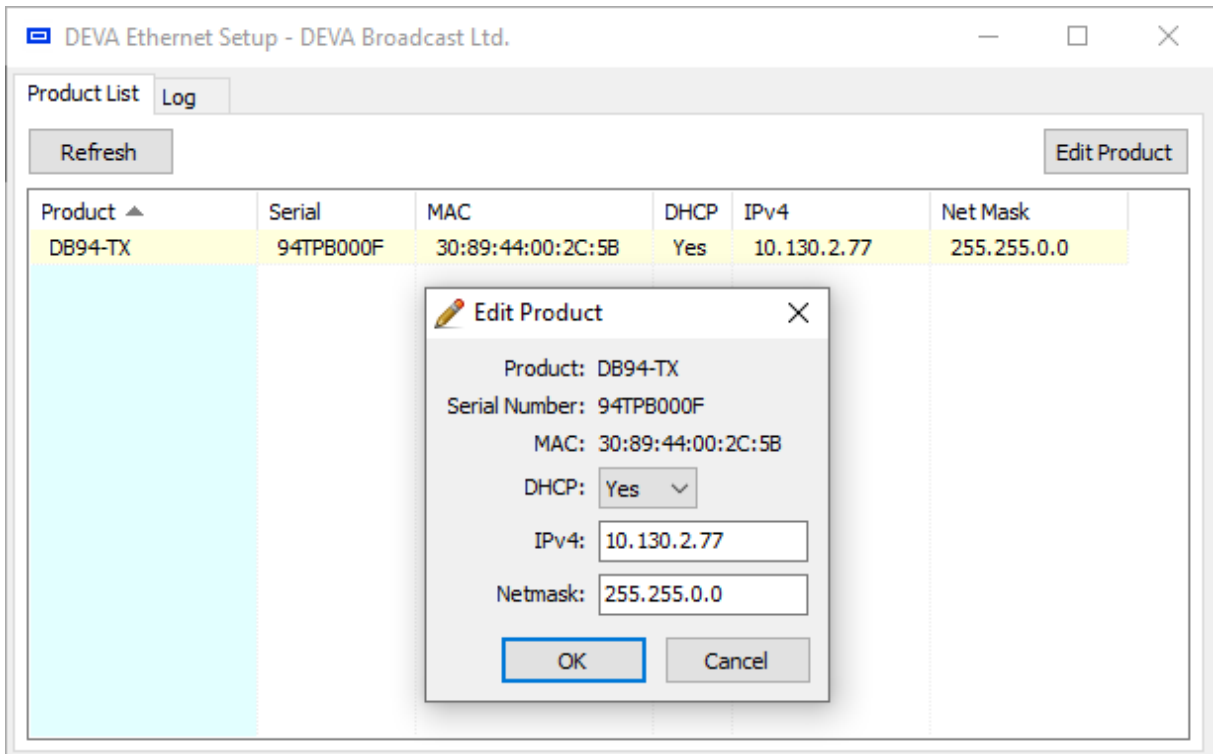

4. Enter the needed changes and press [OK]. Make sure to write down the IP address as it will be needed in order for the device to be accessed via WEB or Software interfaces.

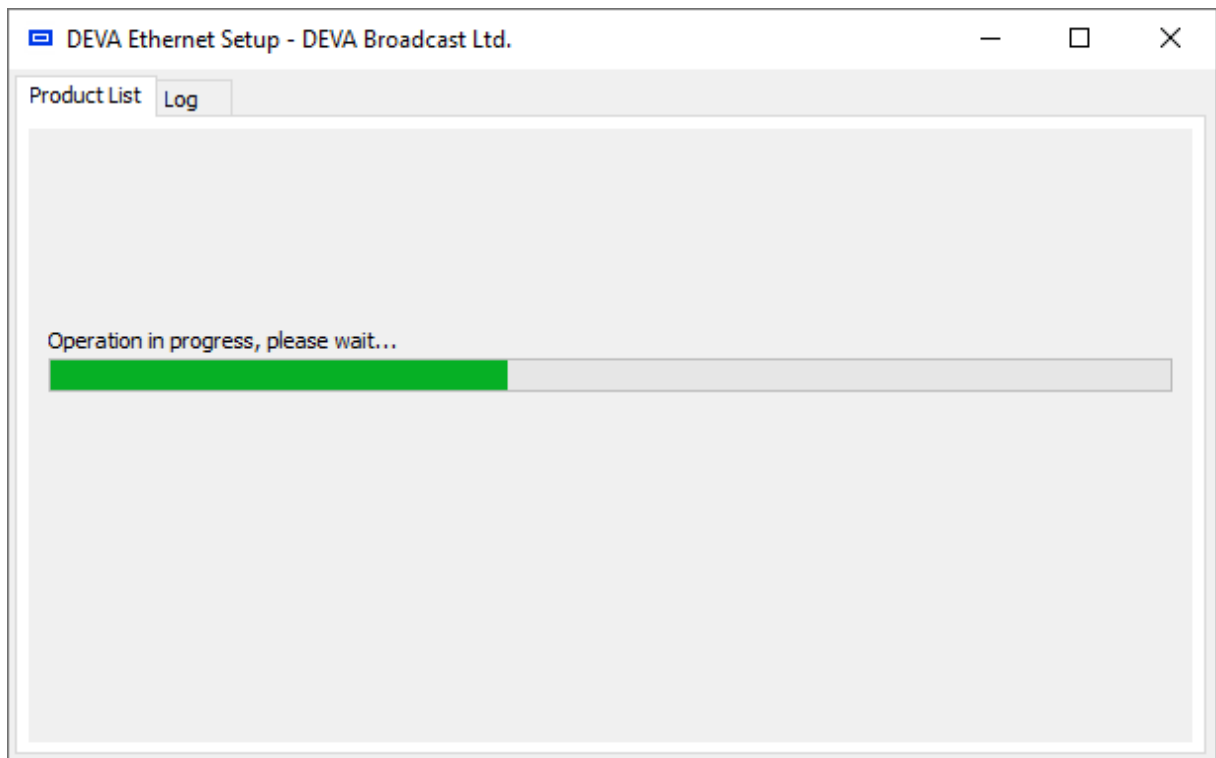

5. A new network scan process will be performed automatically to confirm that the applied settings are accepted.

If you are experiencing any difficulties, or due to any reason the setup process fails, please contact us at support@devabroadcast.com.

About the MicroMPX Codec

The DB9410-TX supports MicroMPX, a custom-developed audio codec created specifically for FM broadcasting. It enables the transmission of high-quality FM multiplex signals over IP using UDP while requiring only 320 kbps of bandwidth. In contrast, some manufacturers offer full-bandwidth, uncompressed MPX over IP solutions, but these demand significantly more dedicated capacity often 2 Mbps or higher.

By comparison, MicroMPX reduces the required bandwidth by nearly 84%, bringing it down to just 320 kbps. This dramatic reduction makes it practical and cost-effective to send high-quality multiplexed audio from virtually any audio processor over an IP network directly to an exciter.

Unlike conventional codecs such as MP3 or AAC, which are optimized for stereo audio, MicroMPX is engineered specifically for composite FM signals. It uses an innovative perceptual masking technique that takes advantage of the inherent characteristics of FM multiplex signals. When used for STL applications, this design offers two key advantages over traditional stereo codecs:

- Artifacts generated by stereo codecs typically require additional downstream processing to correct overshoots and other issues before stereo generation.
- Any artifacts produced by MicroMPX encoding appear as normal FM noise and are effectively imperceptible.

With MicroMPX, broadcasters can now carry MPX signals over lower-bandwidth IP links and narrowband STL paths. This technology opens up new possibilities for audio distribution while reducing both equipment requirements and overall costs by capitalizing on the continued expansion of global IP infrastructure. Sound quality also improves as this specialized codec is deployed more widely. As with any transformative technology, the range of applications for MicroMPX is expected to expand as innovative broadcast engineers explore its capabilities.

A DISTINCTION FROM L/R SIGNALS

It is essential for readers to recognize that the DB9410-TX carries fully modulated FM composite signals rather than discrete left and right audio channels. This composite signal includes all elements required for an FM broadcast, including the L+R program audio, the 19 kHz stereo pilot tone, the L/R stereo information, and RDS/RBDS data on the first subcarrier.

When operating as an encoder, the DB9410-TX converts an analog composite FM signal into IP data packets. In decoder mode, it performs the reverse function, transforming IP packets back into an analog composite FM signal. Consequently, the encoder must be connected to the output of an audio processor, while the decoder is designed to drive the analog composite input of an FM transmitter.

In practical terms, DB9410-TX functions much like a modem for FM broadcasts. For clarity, referring to an FM composite signal diagram can be helpful.

Use Cases & Applications

The diagrams depicted below represent only a few samples of the applications made possible by this modular technology. By using the DB9410-TX, transmitter rack layouts can be simplified, removing the need for additional processing or stereo generation at the transmitter site.

SIMPLE STL: USE WITH ANY FM PROCESSOR

The DB9410-TX is processor agnostic. Composite output of ANY brand of FM processor feeds an MPX Encoder, while the Decoder feeds the transmitter.

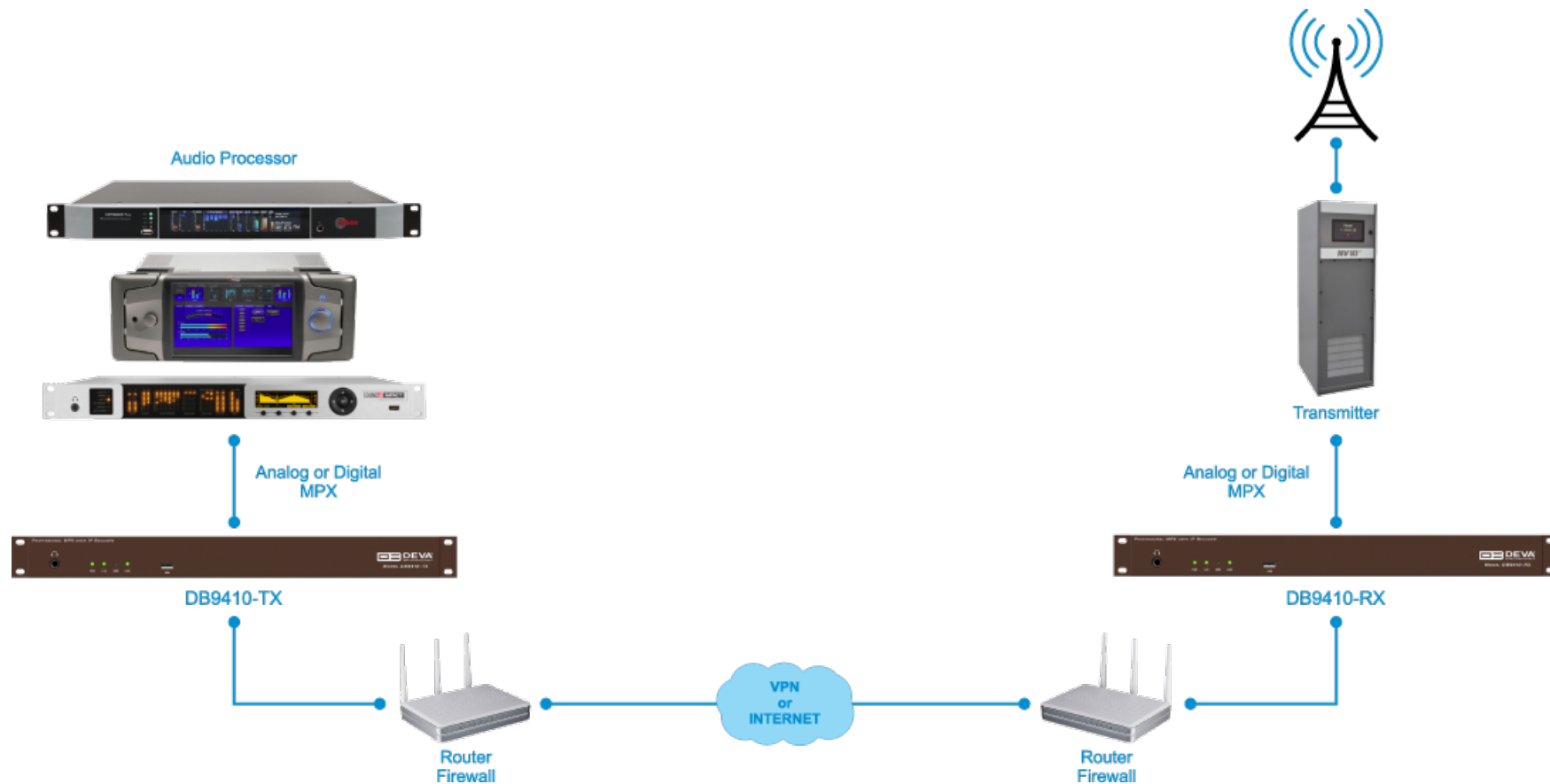

ONE PROCESSOR TO MANY TRANSMITTERS

This diagram highlights one of the key advantages of transporting MPX over IP: every decoder produces an identical replica of the primary processor output.

Whether at the main transmitter, backup facility, or repeater site, each location receives the same signal.

This approach maximizes the benefit of your highest-quality processor, ensures consistent sound across all transmission sites, and eliminates the need for individual tuning and adjustment of each transmission chain.

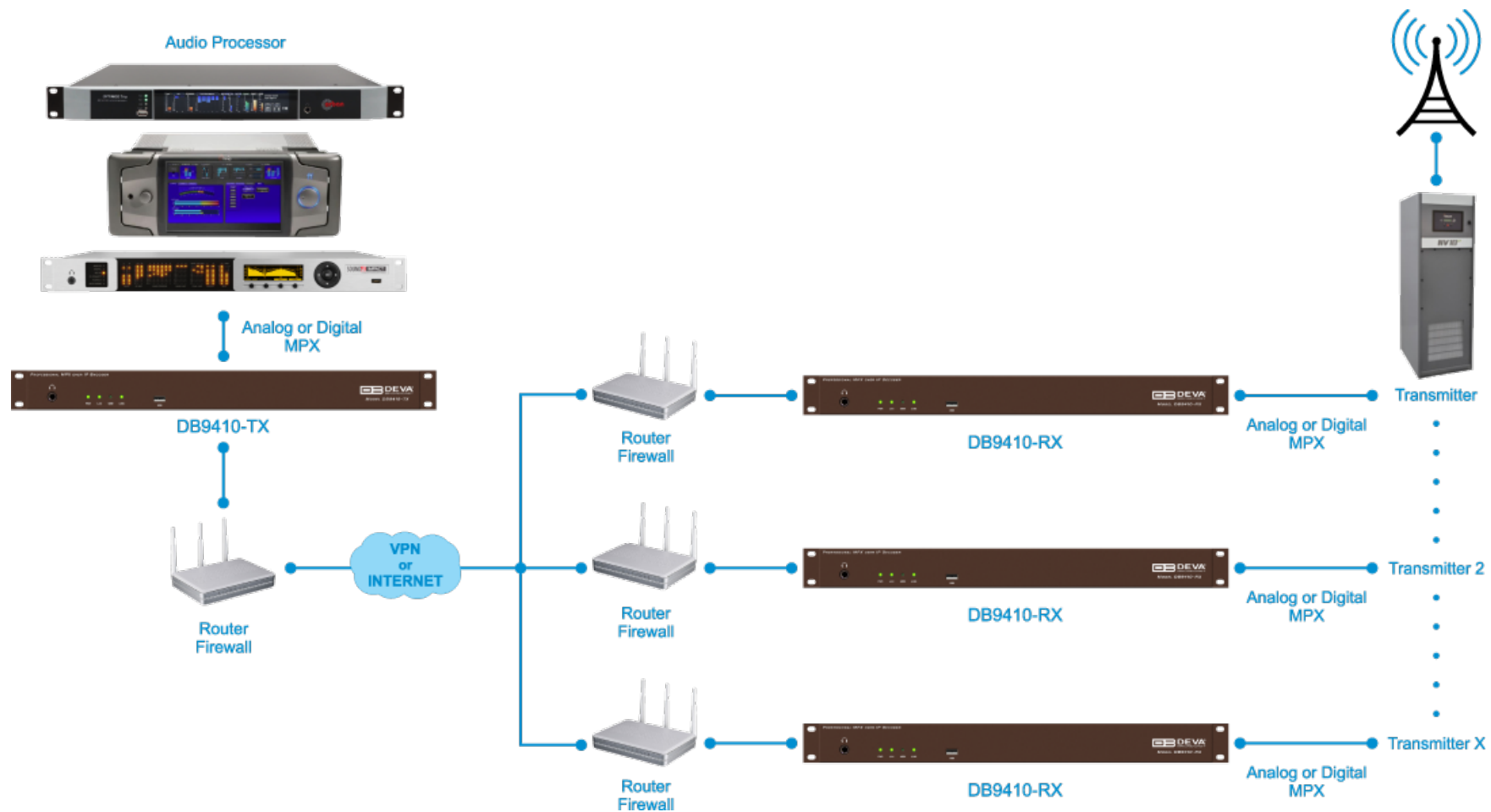

USE WITH PRIVATE NETWORKS AND IP RADIOS

MicroMPX allows lower bandwidth IP connections and narrow band STL channels to be used for MPX signals transport.

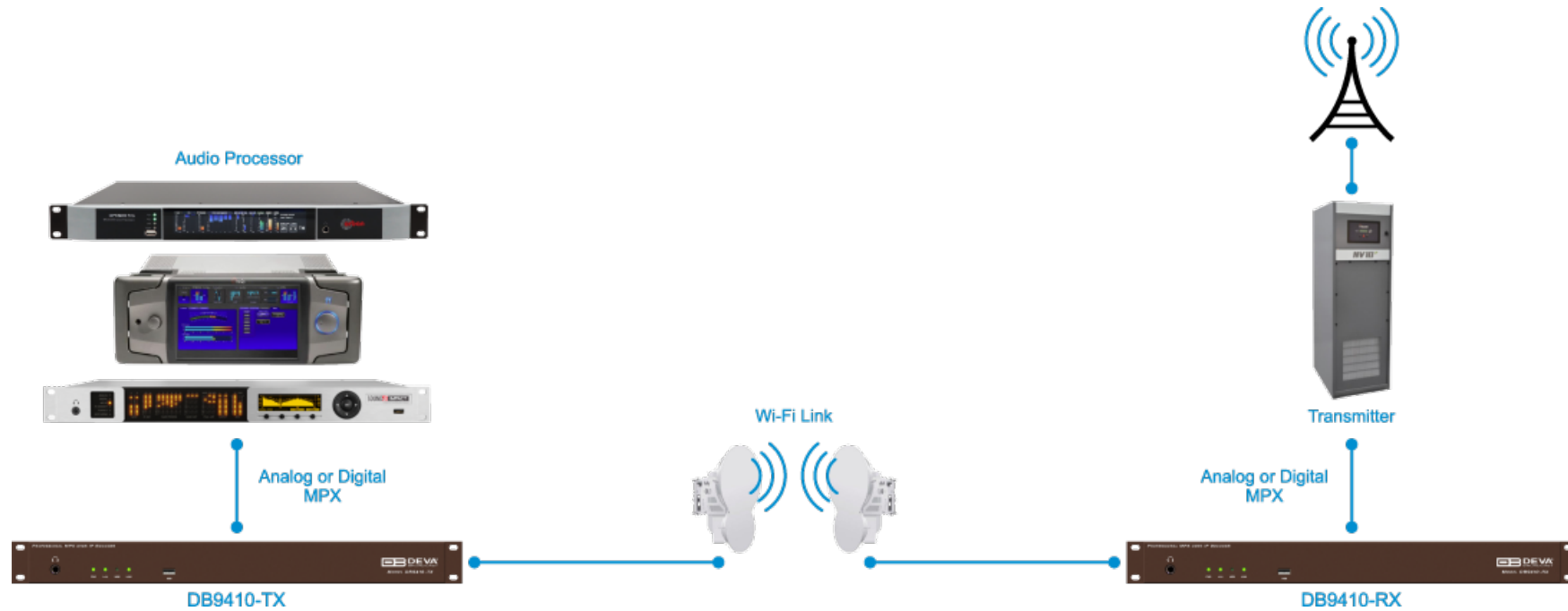

REDUNDANT PATHS AND BACKUP SCENARIOS

Single Encoder & Decoder, Dual Networks

In this configuration, Network 1 and Network 2 ports feed two entirely separate network paths. If packets are lost on one path, the Decoder grabs them from the other and seamlessly re-assembles the stream.

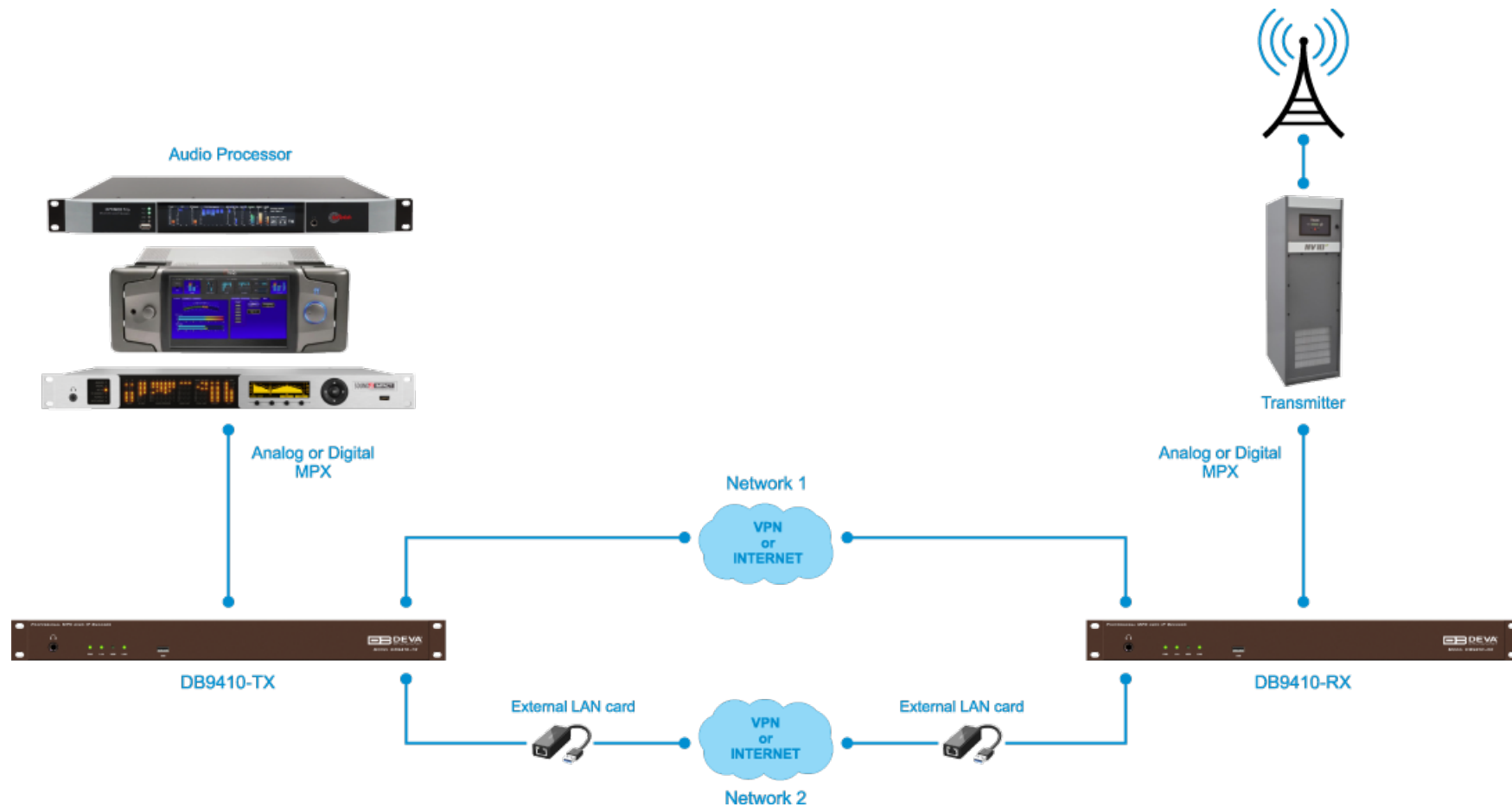

Dual Encoder, Single Decoder

A processor (or 2 processors located at different sites) feeds two Encoders. Both Encoders send the same signal over UDP to a single Decoder at the same IP and port address. If one of the links fails, the Decoder picks up the stream from the other Encoder after a brief failover period. (An external router may be required, depending on your link design).

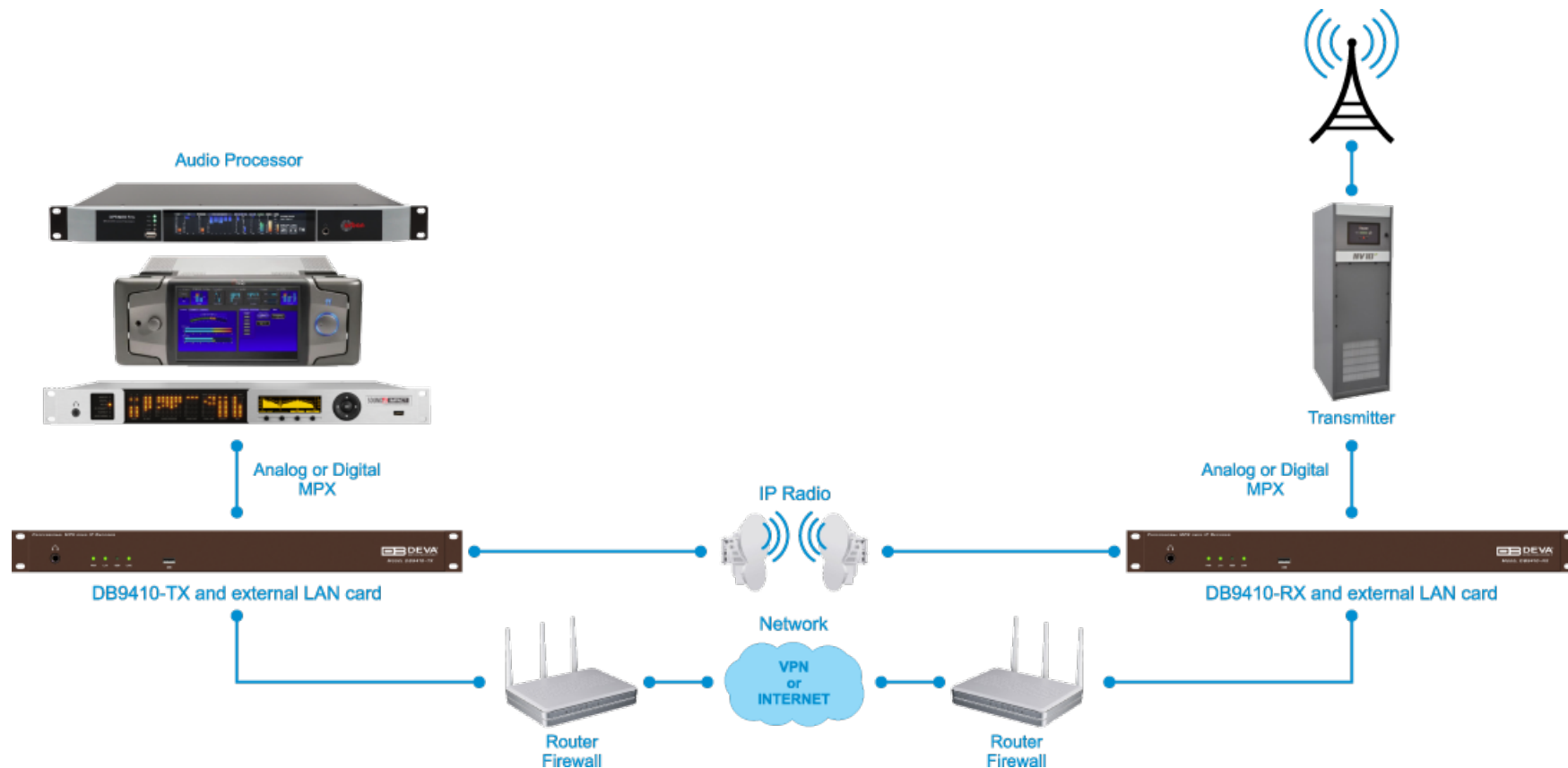

Dual Encoder, Dual Decoder

In this option, a second Decoder is added to the previous usage diagram so that both - the Main and Backup transmitters are both fed with signals served by separate network paths. (Depending on your link design, an external router may be required).

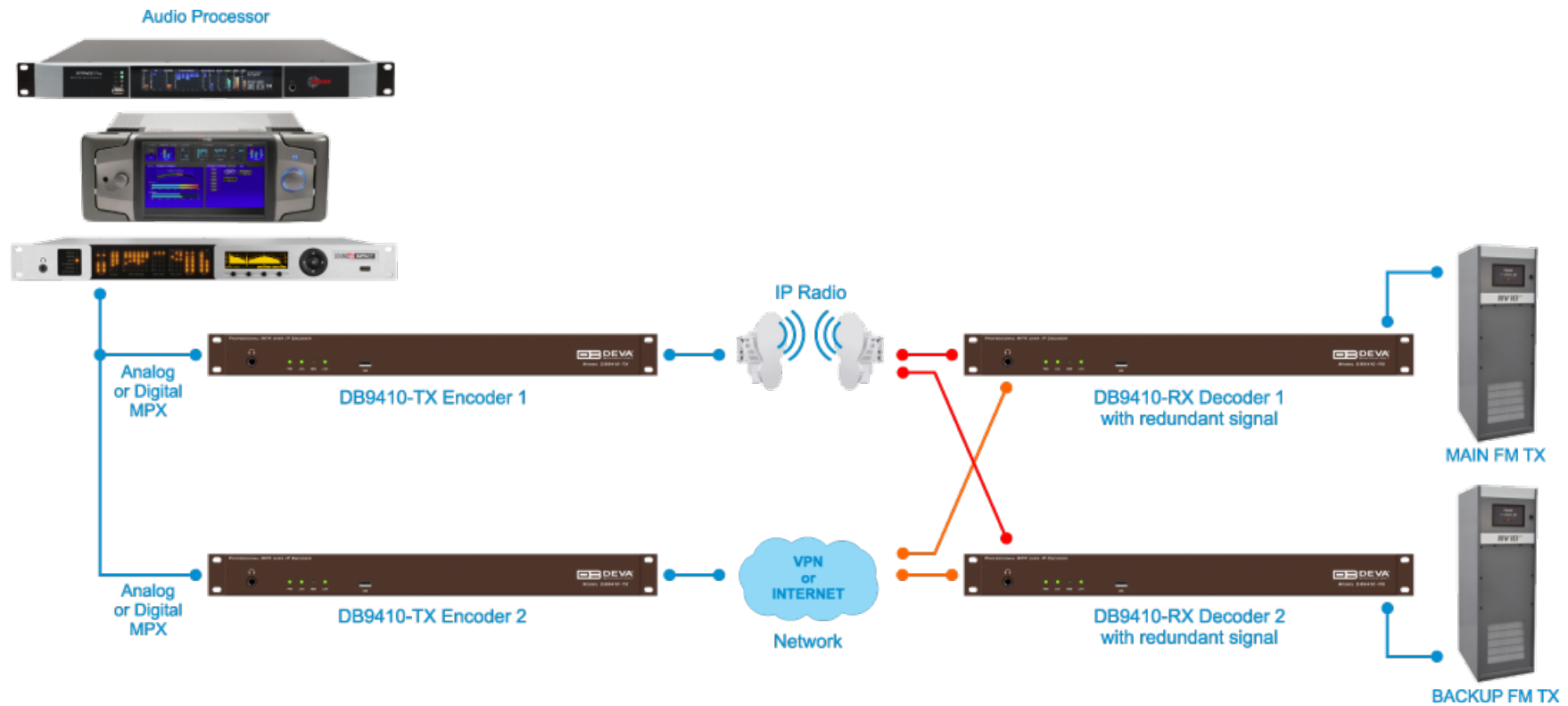

SFN + GPS

Connect the GPS receiver to the encoder's GPIO/GPS port. In general, any GPS receiver capable of sending an NMEA signal to the device's COM port should work.

Place the GPS receiver in a location where it can receive a strong GPS signal, such as near a window.

Each decoder requires a GPS receiver with PPS (Pulse Per Second) support.

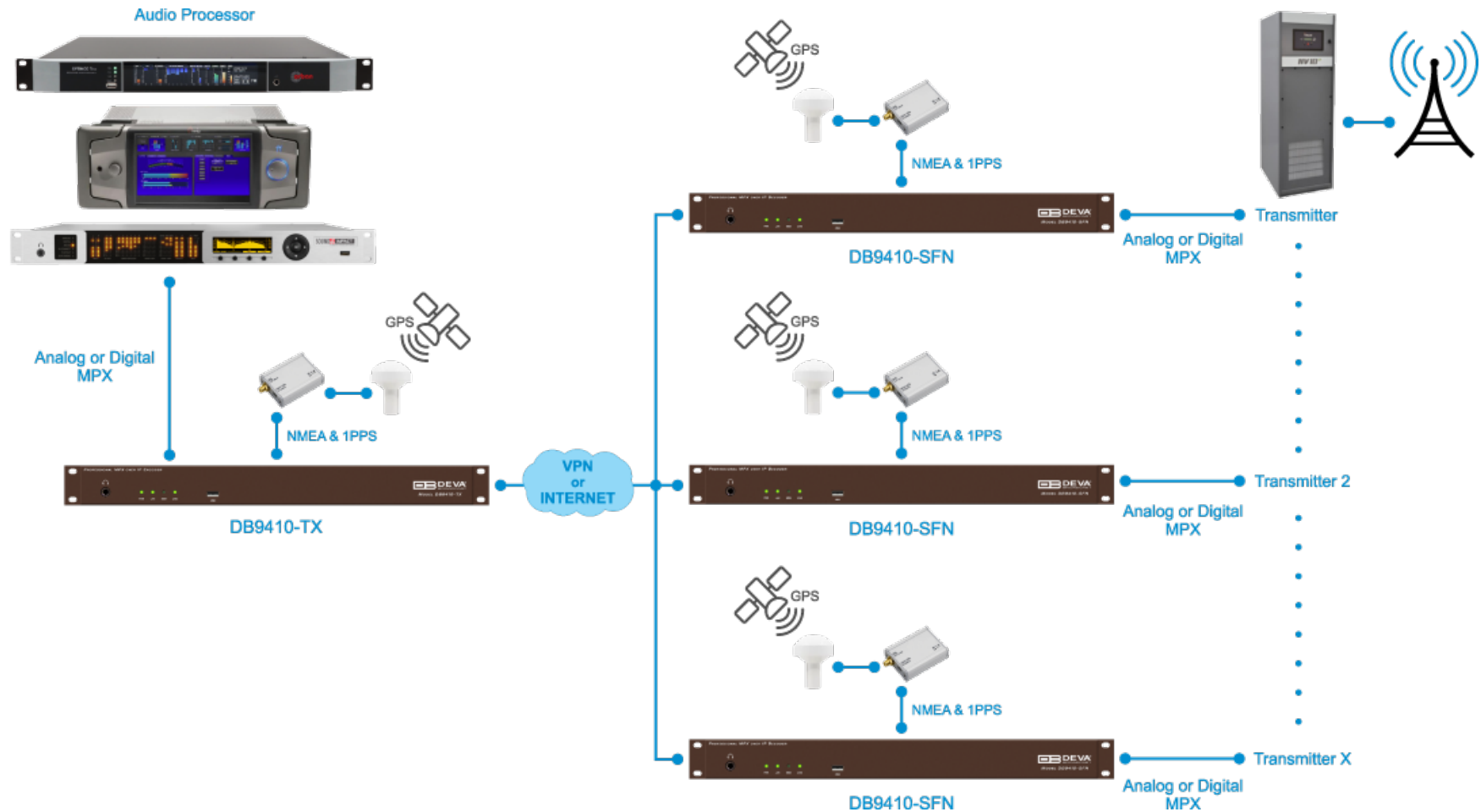

Technical Notes

MICROMPX CODEC SETUP TIPS AND BEST PRACTICES

In order for optimal performance to be guaranteed, the MicroMPX encoder and decoder should be configured to match the quality of the IP connection linking them.

If the encoder and decoder are not set up with sufficient protection against impairments in the data stream, the MPX signal quality can deteriorate suddenly and severely. In such cases, the decoder may mute its output for several hundred milliseconds. Proper configuration depends largely on the characteristics of the IP link-particularly packet jitter and packet loss.

PACKET JITTER

Packet jitter occurs when packets arrive at the receiver at irregular intervals. Some may arrive earlier or later than expected, and in some cases packets may even get reordered.

TIP: To compensate for higher jitter levels, increase the decoder's **Stream Delay** buffer

PACKET LOSS

Packet loss happens when data packets fail to reach the receiver. This can be caused by limited IP bandwidth or by packet corruption during transmission.

TIP: To compensate for packet loss, increase the encoder's error correction settings by adjusting the **Stream Error Correction "Size/Delay"** and **"Overhead"** parameters.

EXAMPLE: If **Size/Delay** is set to 20 and **Overhead** is set to 3, the system can recover up to three lost packets within a block of 20 packets without any audible impact.

As a general rule:

- If packet loss occurs in occasional bursts, increase both **Size/Delay** and **Overhead**, ensuring that **Overhead** does not exceed **Size/Delay**.
- If one or two packets are lost more frequently, use smaller values for both parameters.

Be aware that higher **Overhead** values and lower **Size/Delay** values increase the data rate. For instance, with **Size/Delay** set to 20 and **Overhead** set to 3, every 20 packets generate 3 additional error-correction packets. This raises the total packet count from 20 to 23, increasing the data rate by approximately 15%.

FIREWALL AND SECURITY

The DB9410-TX includes a basic built-in firewall intended to protect the unit from certain network scans and intrusion attempts. This internal protection is not a substitute for a comprehensive external firewall or security strategy and applies only to the DB9410-TX.

The internal firewall blocks selected incoming ports to prevent system services from becoming potential entry points into your network. For optimal security, the use of a properly configured external firewall is strongly recommended.

TILT CORRECTION

DB9410-TX operates with a flat response and assumes the incoming signal does not require tilt correction. If tilt correction is needed anywhere in the signal chain, it must be applied externally to the DB9410-TX.

To determine whether tilt correction is required, send a square wave through the audio processor into the DB9410-TX and confirm that a square wave is displayed on the DB9410-TX's meters.

COOLING

DB9410-TX is designed to dissipate heat through its chassis and exchange it with the surrounding air. To ensure proper cooling, do not obstruct the ventilation openings on the top or sides of the unit, and maintain rack ambient temperatures below 40°C.

As with all electronic equipment, excessive heat accelerates component aging. Maintaining a cooler operating environment will help extend the service life of the unit.

WEB Interface

DB9410-TX is controlled through a built-in WEB Server and a standard web browser can be used to monitor its status or to make some adjustments. To operate the device you need to know its IP Address. In case you are not aware of it use the [“DEVA Ethernet Setup Tool”](#). Then open a new WEB Browser and enter the device IP address in the address field then press [Enter].

ACCESS

DB9410-TX provides you with a protected access to the device settings. To make the necessary adjustments to the device, please log in as an ADMINISTRATOR. The default values being username: **admin**, password: **pass**.

A screenshot of the DEVA web interface login page. The page has a dark blue header with the DEVA BROADCAST logo on the left and a user account menu on the right. The main content area is dark grey and contains a login form with the following elements: a label 'Account', a label 'User name' above a text input field, a label 'Password' above a password input field, and a 'Log in' button at the bottom center.

INPUT

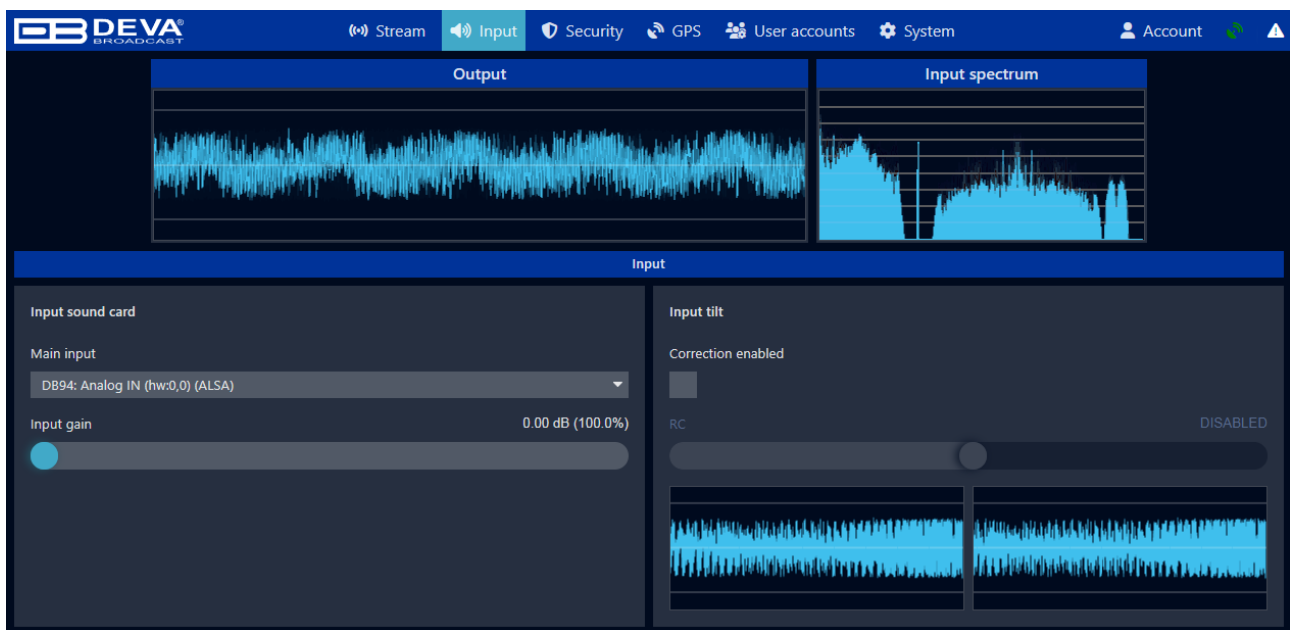

In the Input tab, you can select an input sound card.

IMPORTANT: In order for the MicroMPX to work correctly, the input level has to be at exactly 0 dB. Please adjust the gain slider (if needed) so that the thin lines in the scope display just reach the peaks.

IMPORTANT: If possible, use a digital sound card. Analog sound cards usually have a highpass filter in their inputs, which causes the peak level to become non-constant. If needed, the “Input tilt” correction can be used to compensate for this. This is never needed for digital inputs, but it usually is needed for analog inputs.

These two remarks only apply when you use a MicroMPX encoder that’s not built into an audio processor.

Once done the display should look as depicted above.

STREAM

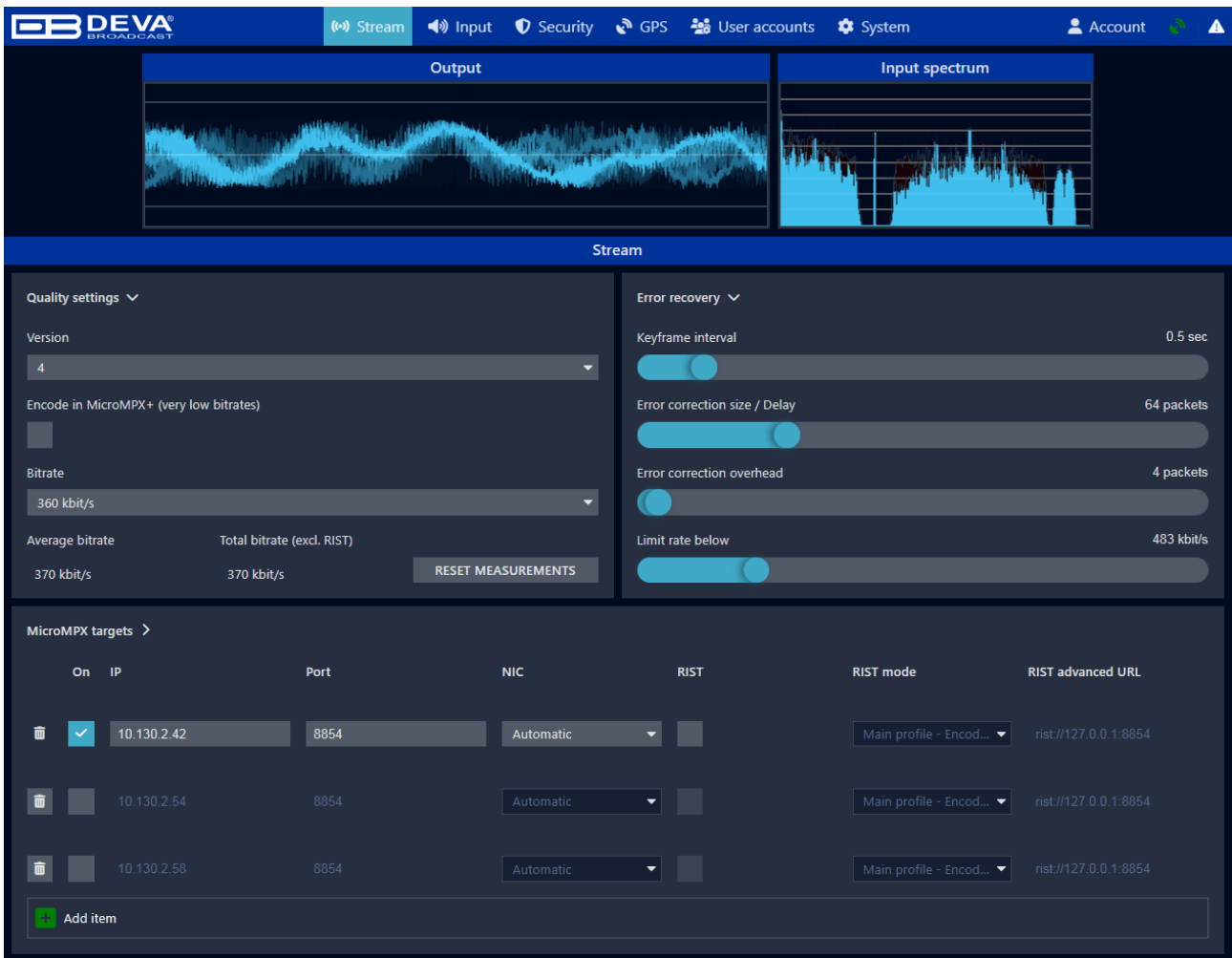

Stream

Quality settings ▾

Version: 4

Encode in MicroMPX+ (very low bitrates)

Bitrate: 360 kbit/s

Average bitrate: 370 kbit/s | Total bitrate (excl. RIST): 370 kbit/s

RESET MEASUREMENTS

Error recovery ▾

Keyframe interval: 0.5 sec

Error correction size / Delay: 64 packets

Error correction overhead: 4 packets

Limit rate below: 483 kbit/s

MicroMPX targets >

| On | IP | Port | NIC | RIST | RIST mode | RIST advanced URL |
|-------------------------------------|-------------|------|-----------|--------------------------|-------------------------|-----------------------|
| <input checked="" type="checkbox"/> | 10.130.2.42 | 8854 | Automatic | <input type="checkbox"/> | Main profile - Encod... | rist://127.0.0.1:8854 |
| <input type="checkbox"/> | 10.130.2.54 | 8854 | Automatic | <input type="checkbox"/> | Main profile - Encod... | rist://127.0.0.1:8854 |
| <input type="checkbox"/> | 10.130.2.58 | 8854 | Automatic | <input type="checkbox"/> | Main profile - Encod... | rist://127.0.0.1:8854 |

Add item

Next, type in the IP address of the decoder device in the Stream window:

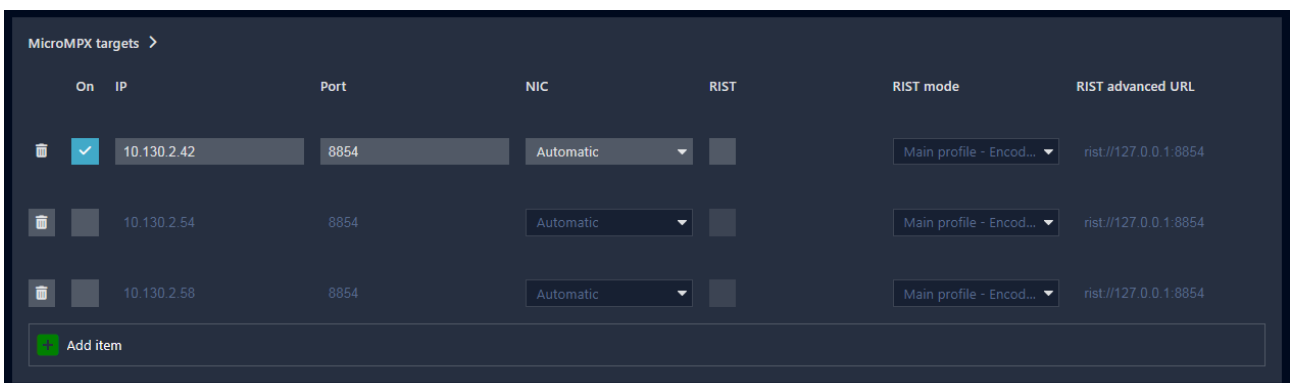

MicroMPX targets >

| On | IP | Port | NIC | RIST | RIST mode | RIST advanced URL |
|-------------------------------------|-------------|------|-----------|--------------------------|-------------------------|-----------------------|
| <input checked="" type="checkbox"/> | 10.130.2.42 | 8854 | Automatic | <input type="checkbox"/> | Main profile - Encod... | rist://127.0.0.1:8854 |
| <input type="checkbox"/> | 10.130.2.54 | 8854 | Automatic | <input type="checkbox"/> | Main profile - Encod... | rist://127.0.0.1:8854 |
| <input type="checkbox"/> | 10.130.2.58 | 8854 | Automatic | <input type="checkbox"/> | Main profile - Encod... | rist://127.0.0.1:8854 |

Add item

The default port for MicroMPX is 8854. If you changed it in the decoder, make sure to use the correct port in the encoder.

Unicast vs. Multicast

DB9410-TX Encoders can transmit either **unicast** or **multicast** streams.

A **unicast** stream is a point-to-point connection, sending IP packets to a single recipient over a network, including the public Internet. Each additional unicast stream increases bandwidth usage at the source.

A **multicast** stream operates in a one-to-many configuration. Packets are sent from the Encoder DB9410 to any Decoder DB9410 on the network that has requested them. Multicast requires a private network, as multicast IP address ranges (224.0.0.0 – 239.255.255.255) cannot be routed over the public Internet.

When using multicast, proper network configuration is essential - particularly Quality of Service (QoS) settings. These requirements will vary depending on other traffic present on the network.

Configuring Streams

The **Output Streams** section allows you to specify the IP address and port number of the destination Decoder.

- If you modify any settings, you must click **Apply** for the changes to take effect.
- Saving a stream takes effect immediately.
- Use caution when editing IP address fields to avoid interrupting an active connection to a decoder.

MicroMPX uses **UDP port 8854** by default.

While you can stream to multiple decoders, all streams must use the same codec and bitrate.

Step-by-step instructions follow:

1. Enter a valid **IP address** and **port number** for the destination Decoder.
2. Select the appropriate **network interface** from the drop-down menu. This determines whether the stream is sent from the **NET 1** or **NET 2** physical port.
3. Set the **Stream** control to the “**On**” position.
4. Click **Apply** to save your settings. If you leave the page without clicking **Apply**, any changes will be lost.

DSCP & TTL Settings (Multicast Only)

The following settings apply to multicast networks:

DSCP (Differentiated Services Code Point)

– Sets the QoS (Quality of Service) packet priority for DB9410-TX data. The default value is **0**. Proper QoS configuration on your network is essential to prevent dropouts or interruptions caused by competing traffic.

TTL (Time To Live)

– Limits how long packets can remain active on the network, preventing them from circulating indefinitely. The DB9410-TX default TTL value is **32**.

MICROMPX ENCODER SETTINGS

Enabling the Encoder

Verify that the **MicroMPX Encoder** is set to **On** in the field at the top of the screen.

If encoding is not enabled:

- The MPX meters on the Dashboard screen will remain inactive.
- The Level % indicator will appear frozen.

MPX Input Level

This gain control allows you to optimize the signal level feeding the DB9410-TX's converters and directly affects overall loudness.

To properly set the input level:

1. Supply a composite input with typical program material.
2. Adjust the control so the level indicator reaches as close to **100%** as possible during normal peaks.
3. Avoid triggering the **Clip** indicator in the upper-right corner.

NOTE: The slider value is not applied until you release the mouse. Once released, the updated gain value will appear on screen.

Clip Indicator

The Clip indicator is calibrated to flash at **105%**.

Although the Encoder includes internal input limiting, frequent clip activity indicates an excessive input level and should be corrected.

- Occasional clip flashes (a few times per day) are generally not a concern.
- Continuous or frequent clipping indicates a problem and requires reducing the input level at the Encoder.

There is no adjustment on the Decoder side to correct clipping caused by excessive input at the Encoder. Additionally, the Decoder does not include a clip indicator, as the signal has already been modulated.

If the Clip indicator remains active consistently, reduce the input level at the Encoder.

Bitrate

The factory default (and lowest) MicroMPX bitrate is **320 kbps**.

Supported bitrates are:

- 320 kbps
- 384 kbps
- 448 kbps
- 576 kbps

Bitrate selection allows you to balance bandwidth usage and audio quality:

- Lower bitrates conserve bandwidth.
- Higher bitrates improve sonic performance.

All supported bitrates provide excellent sound quality, and most listeners will not perceive significant differences. We recommend selecting the highest bitrate your network connection can reliably support.

Bitrates can be changed without audible artifacts.

Additional Notes on Bandwidth

- Bitrates are averaged over time. Short segments of complex audio may briefly require higher data rates than the published value.
- The codec automatically compensates by reducing subsequent data usage.
- Error correction settings add bandwidth overhead. Depending on configuration, error correction can significantly increase total bandwidth requirements.

RIST SUPPORT

Instead of using the standard protocol, you can also choose to wrap all data in RIST. RIST is a protocol that offers a very good error recovery, and allows connecting even if you do not have a static IP address at the decoder sites.

If you have dynamic IP addresses on your decoder sites, or if you have severe dropouts that Forward Error Correction cannot handle, we recommend using RIST.

RIST support is currently experimental, only available in beta versions of MicroMPX.

RECOMMENDATIONS: The rest of this document describes how to set-up the device without RIST. If you are using RIST, you can skip the parts about error recovery and etc. Port forwarding is still needed, but you can choose on which side you will set it – the encoder or decoder.

Some important notes on how to make the best use of RIST:

- Make sure to set “RIST” enabled and “RIST Mode” to the same value everywhere.
- RIST does not use forward error correction; ignore those settings. Instead, it has a “RIST Delay”, that needs to be set high enough in order to handle dropouts. Meaning that if you expect long dropouts, you need to set the “RIST Delay” high.
- RIST Delay causes the display of incoming packets to be delayed as well! So you might not see any action for some time when you enable RIST.
- Aside from RIST Delay, the normal delay is there to handle any hiccups caused by the sending device. Depending on the encoder used, you can set this value low - 0.1 second or so.
- RIST also supports redundant links. We don't currently support that via our normal settings. You can configure it, but for that you'll need to use the Expert mode, and manually enter the RIST URL's. Detailed description about RIST is available in [“APPENDIX - RIST URL Syntax and Examples” on page 61](#) of the user manual.

MICROMPX+ FOR BITRATES DOWN TO 176 KBIT/S

MicroMPX+ is a different codec from MicroMPX, which also requires an extra license. It uses some tricks to lower the bitrate further. In that regard it's comparable with AAC+ vs AAC, or MP3Pro vs MP3, for example.

Alongside the audio, MicroMPX+ also transmits data that describes what type of artifacts have been created by the encoder, and the decoder then attempts to filter out those artifacts. This filtering changes the waveform, and can result in (small and short) overshoots, which require a clipper (which is included) to get rid of. Changes in the waveform may also affect the RF bandwidth that's used, which usually isn't a problem, but if you're using the Stokkemask (ITU recommendation ITU-R.SM1268) filter in Stereo Tool, or RF bandwidth control in BreakAway, BaOne, Omnia.7, 9 or 9sg, you can't rely on that it fully survives the codec anymore, especially at the lowest bitrates.1

In the end, for listeners it shouldn't be possible to notice any difference if you switch to MicroMPX+ with lower bitrates.

MICROMPX+ VARIABLE BITRATE FOR EVEN LOWER BITRATES

If you want to go even lower in bitrate, for example if you have to pay for the bandwidth that's actually being used instead, you can enable Variable Bitrate mode. This is especially useful for talk radio stations with moments of (near)-silence and mostly mono content.

Both MicroMPX and MicroMPX+ will always use all the available bandwidth to encode the incoming signal as precisely as possible, unless there is no information to encode anymore, which means that typically only pure silence causes the bitrate to drop below the configured bitrate. But since FM reception has a noise threshold, for (near) silence it doesn't really matter what the encoder sends. Aside from this, if the audio quality is good for stereo sounds, which requires encoding of both the L+R and (potentially asymmetrical) L-R parts of the band, it's safe to drop the bitrate considerably for mono content, which is easier to encode.

Variable Bitrate allows you to set a noise threshold level, thus increasing the chance that the bitrate drops below the configured value. This is somewhat similar to reducing the number of bits per sample, which is sometimes also used to reduce bitrates (with dithering). For music (except classical music), the effect will usually be very small, but for speech it can be quite big. Talk stations typically achieve average bitrates below 100 kbit/s, using a high enough VBR threshold at 176 kbit/s.

The artifacts created by the dithering of the audio are included in what the MicroMPX+ encoder reports to the decoder, so what comes out is filtered and sounds better than just dithering it would. The 19 kHz stereo pilot and RDS areas of the spectrum are not affected by the VBR noise threshold setting.

MICROMPX ENCODER CONFIGURATION

Forward error correction

MicroMPX streams over UDP, which is susceptible to packet loss on busy or unstable networks. It contains multiple mechanisms to ensure stable streaming even when packet loss occurs.

The easiest one to use is Forward Error Correction. Here's what a typical setup looks like:

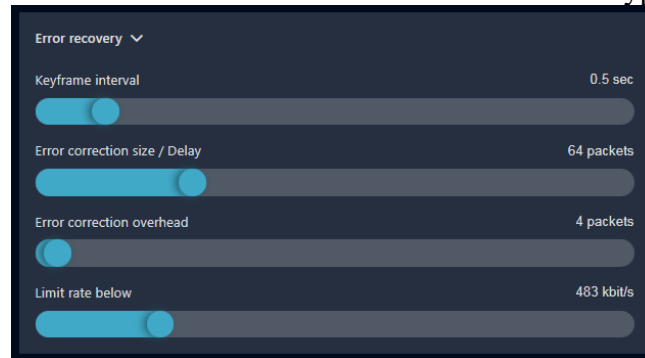

These settings mean that every 64 packets, send 8 extra packets as overhead. For each original 64 packets, 72 actual packets are sent. Meaning that as long as at least 64 of the resulting 72 packets are received, the decoder can reconstruct all the missing packets.

The resulting bitrate is slightly higher than the configured bitrate. For example, when the bitrate is set to 320 kbit/s, and 64/8 is used as recovery settings, the resulting bitrate is $320 + 320 * 8/64 = 360$ kbit/s.

Network dropouts typically occur in bursts, so typically you'll see a number of subsequent packets getting dropped. This means that in the end, it doesn't really make a lot of difference for how resilient the signal is against packet drops whether you set it to 64/8 or for example 32/8 or 128/8. You might think that 128/16 is similar to 64/8, but it is actually (almost) twice as powerful, at the same bitrate ($320 + 320 * 16/128$ is also 360).

There are two settings (64/8). The first value determines how much time there is between blocks of recovery packets. MicroMPX sends about 94 packets per second, not counting the recovery packets, so when you use 64/8 the latency of the decoder must be at least about 0.7 seconds. For 128/16 it needs to be 1.4 seconds. You should set the value a bit higher than this to account for small differences in speeds and the time it may take to send FEC packets; using 1 and 2 seconds in these example cases is definitely safe.

As an example, let's say that according to the error logs, the biggest drop that has been reported was a drop of 5 packets. In that case, you'll want to make sure that all the drops of up to and including 5 packets will be recovered, so the "Error correction overhead" must be set to at least 5 packets. We recommend it to set it a bit higher to also recover slightly longer dropouts. If you want to keep your delay at at most 1 second, you can set the "Error correction size" to around 64 packets. If you don't mind having more latency, you can set that value higher without really affecting recovery, as described above.

The Keyframe interval determines how often a keyframe packet is sent. If the connection is really lost, or if the decoder switches to a different stream or is initially started, playback can only (re)start on keyframes. If a packet would be lost, playback will halt until the next keyframe is received. Setting the time between keyframes lower will therefore result in shorter dropouts if a dropout occurs. Setting the keyframe interval lower will leave slightly fewer bits for data, but it doesn't really have a big impact, so you can safely set it to 0.5 seconds for example.

Finally, Limit rate below - controls how fast packets can be sent through the network. Normally, you can leave this at the default setting. All recovery packets in a block are generated at once. If the number of recovery packets is high, this can lead to many packets being sent to the network at high speed. This could cause packet loss. So, without rate limiting, adding a lot of recovery

packets would actually make the connection less reliable. Because of this, it's better to leave this setting slightly higher than the theoretical value calculated above (the bitrate multiplied by the error correction factor), and always lower than the maximum network capacity available.

Redundant links

In the encoder under Stream, you can add more destinations. For redundancy, if you have multiple connections between encoder and decoder (for example two different ISP's, a satellite connection and a link, or any combination), you can send copies of the same stream via different links. This way, as long as a packet arrives via any of the links, it will be received and decoded.

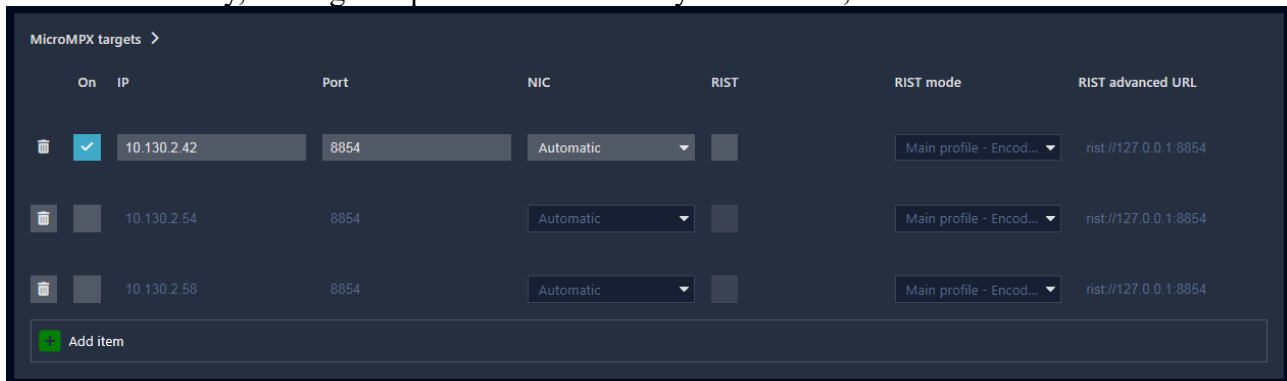

In most cases, the network layer of the operating system can determine based on the target IP address which NIC (network interface, basically which network connector) to use. If you want to explicitly send the data over multiple networks it is not unlikely that an IP address is reachable via multiple connections. To force the encoder to use two different NIC's, you can explicitly specify which NIC to use.

There is also another way to add redundancy. A MicroMPX decoder will “lock onto” a stream that it's decoding. So even if another stream is sent to the same port of the same device, it will keep playing the stream that it's playing. But, if that stream drops out, it will start decoding again at the first keyframe that it receives. That can be a keyframe of the same stream, but also of another stream that's sent to the same decoder port. This makes it possible to have 2 encoders, for example in different locations, that encode the same signal. If one of the two drops out, the decoder will automatically switch to the other one.

Multiple decoders

You can use the same mechanism to send data to multiple decoders. At this moment, upto 100 IP addresses can be used.

As long as you keep the Delay setting in the decoders the same, and there are no large differences in delays in some of the paths (which might be the case for example for a satellite link), all decoders will play the audio at the same moment in time within a few milliseconds, which is good enough for seamless RDS AF frequency switching. If a link does have a delay, the Delay setting for that decoder can be adjusted to compensate for it. If you need the signals to be even more accurate for Single Frequency Networks, see below.

Port forwarding and networks

So at this point you're ready to take the decoder to your transmitter site and connect it to your transmitter. If that's on the same local network as the studio, you can skip this step. But if the data goes over the internet, or another router, you will probably need to configure port forwarding: You need to “instruct” the router that UDP packets that are targeted at the decoder must be allowed through. You will also need to specify where they need to go.

To apply the needed settings, you need to login to your router, and setup port forwarding. Typical

router IP addresses are 172.22.16.1, 192.168.1.1, 10.10.10.1. The login password is usually found on a sticker placed on the router. Then, find the “Port forwarding”/“Virtual server” or something section. The latter often allows you to route data to another port number internally than externally.

This image depicts a setup that sends incoming signals from ports 5550-5558 to different devices in the local network:

NAT **Port forwarding** Virtual Server Special Applications ALG UPnP Quality of Service USB port

Entries in this table allow you to automatically redirect common network services to a specific PC behind the NAT firewall. These settings are only necessary if you wish to host some sort of server like a web server or mail server on the local network.

Enable Port Forwarding

| Local IP | Type | Port range | Comment |
|----------|--------|------------|---------|
| | Both v | | |

Add Reset

Current Port Forwarding Table:

| NO. | Local IP | Type | Port range | Comment | Select |
|-----|---------------|------|------------|-----------------|--------------------------|
| 1 | 172.22.16.101 | BOTH | 5550 | uMPX Nijmegen 1 | <input type="checkbox"/> |
| 2 | 172.22.16.101 | BOTH | 5553 | uMPX Helsinki | <input type="checkbox"/> |
| 3 | 172.22.16.100 | BOTH | 5552 | uMPX Nijmegen 2 | <input type="checkbox"/> |
| 4 | 172.22.16.101 | BOTH | 5551 | uMPX Benidorm | <input type="checkbox"/> |
| 5 | 172.22.16.101 | BOTH | 5554 | RN7NL | <input type="checkbox"/> |
| 6 | 172.22.16.101 | BOTH | 5558 | uMPX Belgium | <input type="checkbox"/> |

Delete Selected Delete All Reset Apply Cancel

If you do not know the IP address of the decoder it is need to be filled in in the encoder), you can find the information on a site like <https://www.whatismyip.com/>. Just open it from the decoder’s side and it will show you the public IP address.

SECURITY / PASSWORD PROTECTION

The screenshot displays the DEVA Broadcast web interface. At the top, there is a navigation bar with the DEVA logo and several menu items: Stream, Input, Security (highlighted), GPS, User accounts, System, and Account. Below the navigation bar, there are two main panels: 'Output' on the left, showing a real-time audio waveform, and 'Input spectrum' on the right, showing a frequency spectrum plot. Below these panels, a blue bar indicates 'Password Protected Stream'. The main content area is titled 'Security' and contains several controls: a 'Password protect stream' checkbox, an 'Active hash' checkbox, a 'New password' text input field, and a 'New hash' text input field. To the right of the 'New password' field is a button labeled 'Password to hash', and to the right of the 'New hash' field is a button labeled 'Activate hash'.

Allows you to password protect the stream.

IMPORTANT: If you're streaming over a public internet connection and other people could potentially send data to the same IP:PORT combination, they could overrule your stream.

You can use a hashcode to protect against that. Only streams coming from an encoder which uses the same hashcode will decode as valid audio. A hashcode can be typed in directly, or generated from a "password". Note that if someone has access to the web interface, they can copy the hashcode and override your stream (but they could do that anyway if they have access).

The hashcode must be identical in the encoder and all the decoders, any mismatch will cause the decoder to go silent, and you'll get lots of error messages because the packages that arrive will be decoded incorrectly and contain garbage. So if you turn this on, it must be enabled in both the encoder and all the decoders.

You can either generate the hash from a password (which can be easy to remember, so you can type it in on all units and hit "Password to hash"), or you can copy the hash itself, which is probably more difficult to remember, but it also means that if you forget the password and you have a network of 200 decoders and you want to add one, you don't need to set a new password on the other 200 units.

GPS SYNCHRONIZATION

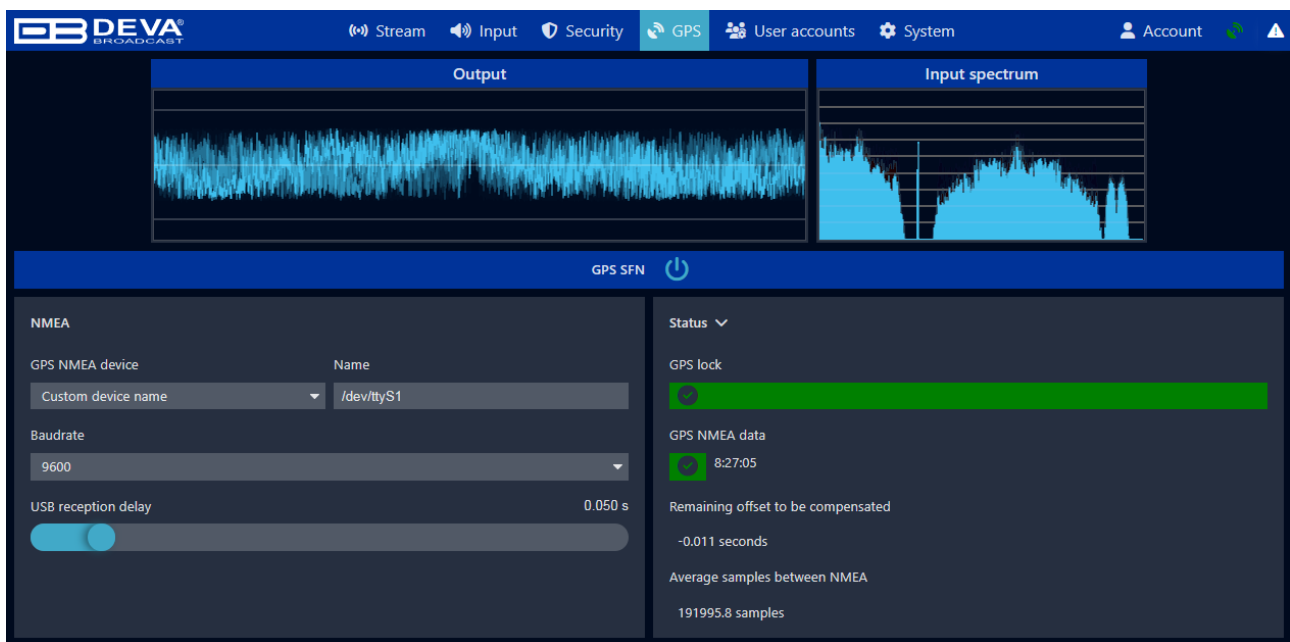

MicroMPX will normally keep your decoders in sync within a few milliseconds, which is good enough for seamless RDS AF switching. But if you have a Single Frequency Network (multiple transmitters at the same frequency with overlapping reception areas) and you want to control exactly where the signals add up instead of interfere with each other, you need accurate timing. Typically, a precision of less than a microsecond is required (one millionth of a second).

To do this, the MicroMPX encoder needs to add timestamps to the audio, and all the decoders need to precisely synchronize when they play the audio using a GPS clock.

For each decoder, you need a GPS receiver with PPS (Pulse Per Second), NMEA support.

Encoder

For the encoder, we sell a GPS receiver that is fully compatible with the DB9410 series. Alternatively, you can use your own – the GPS receiver must be able to send NMEA data to a COM port and a 1PPS pulse signal to the DB9410 device.

Connecting a third party GPS receiver

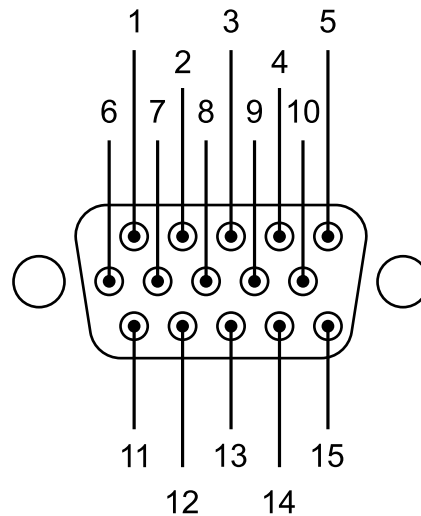

DB15 HD, Male

| Pin | Function | Direction |
|-----|----------------|---|
| 1 | GPI2 | Opto isolated Input |
| 2 | GPS RX | GPS Communication Output |
| 3 | 5V GPS | GPS +5V, Fuse protected (0.5A) |
| 4 | GPO3 | Solid State Relay |
| 5 | GPO1 | Solid State Relay |
| 6 | GPI3 | Opto isolated Input |
| 7 | GPI1 | Opto isolated Input |
| 8 | GPS TX | GPS Communication Input |
| 9 | PPS IN | GPS PPS (Pulse Per Second) Input |
| 10 | GPO2 | Solid State Relay |
| 11 | GPICOM | Common GPO rail |
| 12 | GP5V | +5V (Out), Fuse protected (0.5A) |
| 13 | GPS GND | GPS Ground |
| 14 | GPGND | GPIO Ground |
| 15 | GPOCOM | Common GPO rail |

5V GPS & GPS GND – power supply for the GPS module. **NOT TO BE USED FOR GPIO.**

GPS TX – Input - RS232 NMEA0183 serial communication with the GPS module.

GPS RX – Output - RS232 NMEA0183 serial communication c GPS module

PPS IN – Input - PPS (Pulse Per Second) signal from the GPS module

Connect the GPS receiver to the DB9410-TX. Then connect the DB9410 with the GPS receiver cable provided with the DEVA GPS Receiver set.

Then, go to GPS in the decoder web interface and enable the SFN synchronization:

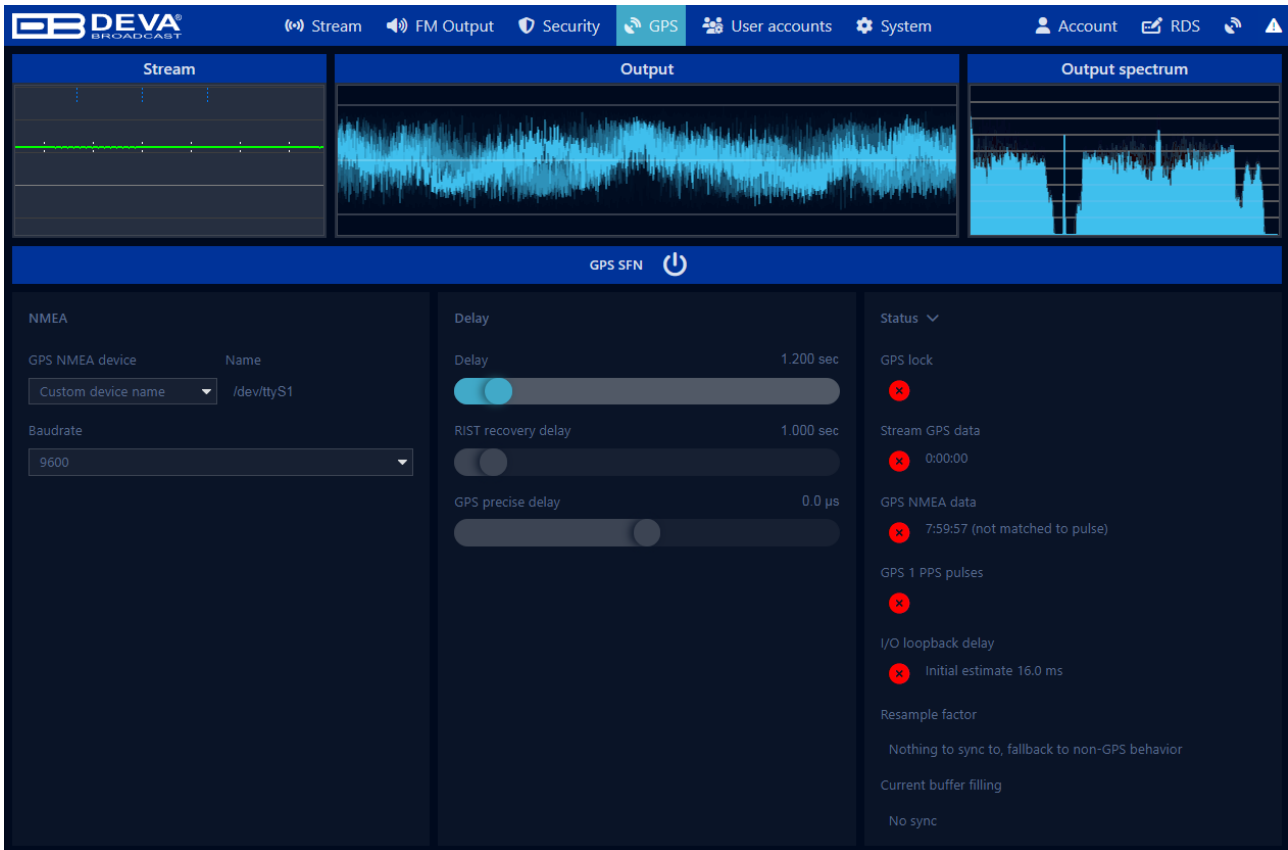

Initially, the GPS timestamps from the encoder, the timestamps of the GPS receiver on the decoder and the time (in samples) between 1PPS pulses will be displayed. If enabled, the I/O loopback delay will show an estimated delay time in milliseconds.

If the 1PPS pulses and loopback delay values don't appear after a few seconds or if they jump wildly, you may have swapped the left and right channels, so try swapping them. The right output channel (the one that contains the audio used for loopback delay measurements) sounds like a constant beep, so if you hear that where you expect your MPX signal, the output channels are probably swapped.

After about 30 seconds, the I/O loopback delay will light up and show an exact time (the measurement is accurate with a precision of 0.01 microseconds).

As soon as the GPS signal is recognized and synchronized to the signal from the encoder (so make sure that the encoder is sending GPS timestamps), the GPS lock icon will light up as it did in the encoder. As soon as that's the case, usually within 2 minutes, if you have multiple decoders that are configured identically and show a GPS lock, the audio is synchronized. The offset in the delays of the decoders should now be constant within about 0.5 microseconds.

To fine-tune where the signals interfere and where they boost each other, you can use the "GPS precise delay" slider. Make sure though that the main "Delay" slider is set to the same setting for all decoders.

NOTE: It may take a few minutes before the GPS receiver gets a lock, and it needs to be placed such that it can "see" enough satellites – so if you're inside a big metal building it might not work. Usually, placing it close to a window will suffice.

First, the GPS NMEA data will appear. After about 30 seconds, GPS lock will light up (both the name under Status and the GPS symbol in the top right corner of the screen):

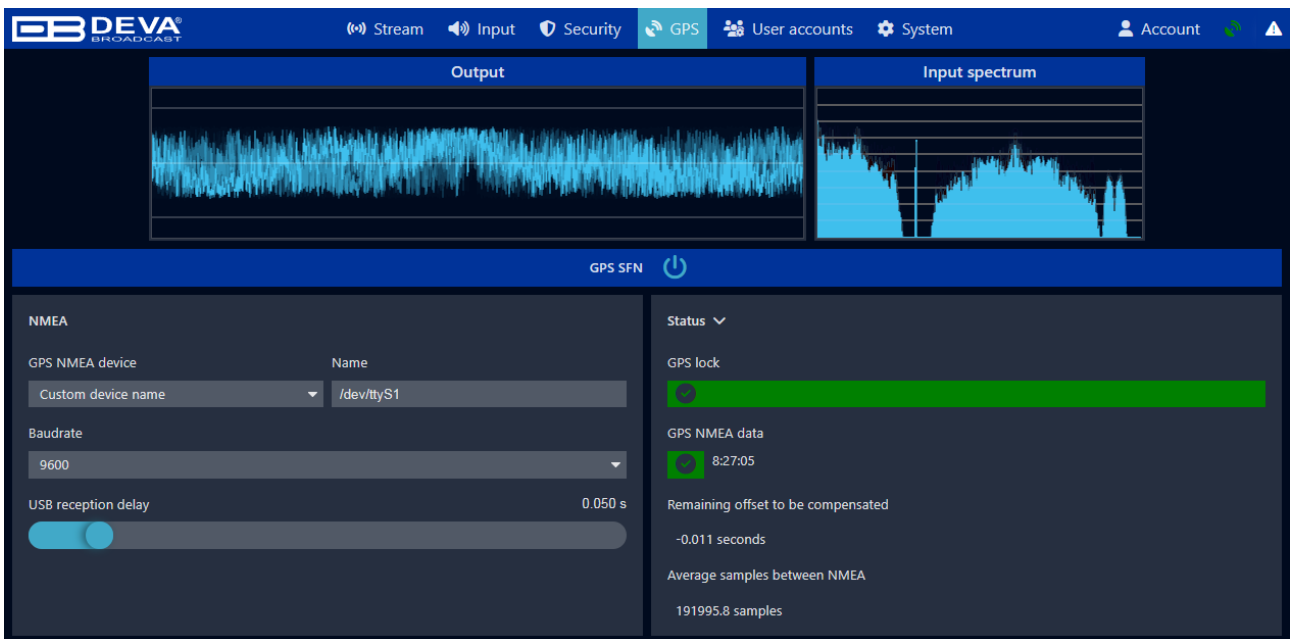

That's all for the encoder end, the MicroMPX bitstream now contains GPS timestamps.

ENCODER DASHBOARD

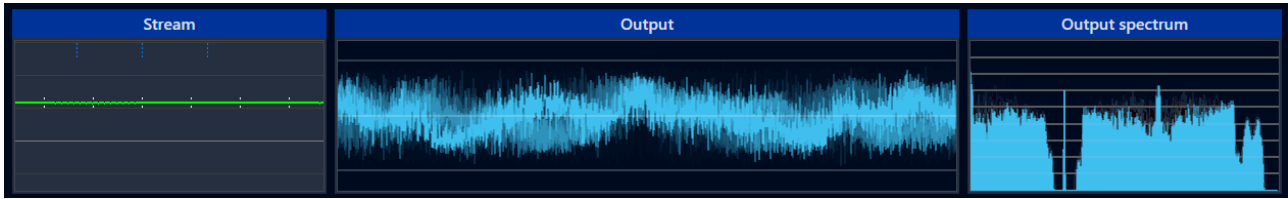

Stream Error Correction

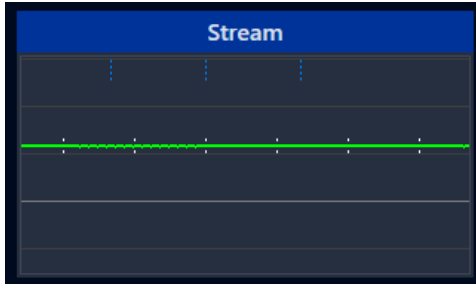

MicroMPX incorporates an advanced error correction system that transmits correction packets along with the multiplexed audio stream. Enabling error correction improves reliability but requires additional bandwidth.

The settings in this section determine:

- How frequently error correction packets are sent
- How many packets are included in each group

Delay Size and Overhead

Delay Size and **Overhead** work together and must be configured carefully.

Important guidelines:

- The **Overhead** value must never exceed the **Delay Size**.
- The combined total of **Delay Size** + **Overhead** must never exceed **255**.

A **bandwidth limiter** is available to prevent error correction overhead from exceeding the available network capacity.

Calculating Bandwidth Usage

Total bandwidth consumption can be calculated using the following formula:

$((\text{Error correction overhead} / \text{Error correction size} / \text{delay}) * \text{bitrate}) + \text{bitrate} = \text{maximum bandwidth utilized.}$

EXAMPLE:

If:

- Bitrate = 320 kbps
- Delay Size = 64
- Overhead = 8

Then:

$$320 + 320 * 8 / 64 = 360 \text{ kbps.}$$

This represents approximately a **12% increase** in bandwidth usage.

When to Use Error Correction

Error correction is **disabled by default**.

On a stable, high-quality data connection, it may not be necessary. However, if you experience audio dropouts or observe **red vertical lines** on the Decoder data display, consider:

- Enabling error correction on the Encoder
- Increasing delay on the Decoder to buffer additional data at the receiver

Proper adjustment of both settings can significantly improve stream stability on less reliable networks.

Stream Display – Things to Note

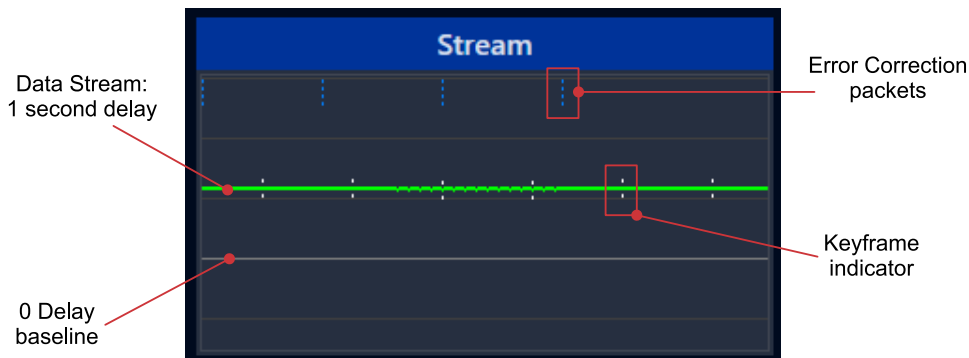

Grey Horizontal Line

Represents 0 delay.

Green Line (Incoming Stream)

The green line shows your incoming stream. Its horizontal position on the graph reflects the delay configured in the Setup screen.

- In this example, the delay is set to 1 second.
- As delay increases, the green line moves upward.
- A smooth, steady green line indicates good and consistent stream quality.

White Vertical Marks (Keyframes)

The short white lines intersecting the green line represent Keyframes.

- This example shows a 5-second keyframe interval.

Blue Vertical Lines (Error Correction Packets)

Blue lines indicate transmitted error correction packets.

- Their density is controlled by the two Error Correction slider settings.
- Increasing error correction results in more blue lines.
- This example shows a Delay Size of 64 with 8 Overhead packets, which is a good starting point if error correction is required.

Red Vertical Lines (Packet Loss / Errors)

Red lines indicate lost packets or transmission errors.

If you frequently observe packet loss on the Decoder side:

- Adjust error correction settings
- Select a lower bitrate
- Increase Decoder delay
- Check network stability
- Verify external QoS settings
- Inspect routers or other network components

If persistent dropouts cannot be resolved, consider transmitting redundant streams over two separate networks ([see “Redundant Paths and Backup Scenarios” on page 31](#)).

Keyframe Interval

The MicroMPX server periodically sends reset packets (keyframes) to maintain synchronization.

- The default (and maximum) interval is **5 seconds**, which is sufficient for most stable connections.
- Reducing the interval sends reset packets more frequently.
- More frequent keyframes allow audio to recover faster after a dropout.
- Keyframes are slightly larger than standard packets, meaning slightly fewer bits are available for MPX data.

Error Correction Size (Delay Size)

The Error Correction Size setting defines the number of packets in each recovery block.

For example:

- A setting of **64** means recovery packets are sent at the end of each 64-packet block.
- Larger block sizes require more Decoder delay (latency) to allow sufficient time for packet recovery.

µMPX transmits approximately **94 packets per second**.

If the block size is set to 94 packets, more than **1 second of Decoder delay** is required to allow proper recovery.

Additional notes:

- A setting of 0 disables error correction.
- Smaller values send recovery packets more frequently but increase bandwidth consumption.
- Larger values are more bandwidth-efficient but require greater Decoder delay.

Proper balance between delay, overhead, and available bandwidth is essential for optimal performance.

Error Correction Overhead

The Error Correction Overhead setting determines how many recovery packets are sent during each error correction block (Size interval). It works in conjunction with the **Size (Delay)** value.

- A value of 0 disables error correction.
- Because packet loss typically occurs in bursts, Overhead is generally more critical than Size for successful recovery.

Understanding Size vs. Overhead Trade-Offs

With the same Overhead ratio, you can adjust the Size value to balance:

- Bandwidth overhead
- Decoder latency
- Burst recovery capability

Examples:

- Size = 64, Overhead = 8
 - Same proportional overhead as Size = 32, Overhead = 4
 - Can recover bursts of up to 8 lost packets (instead of 4)
 - Requires higher decoder latency
- Size = 32, Overhead = 8
 - Similar recovery strength
 - Twice the bandwidth overhead (blocks are sent twice as often)
 - Requires lower latency

Larger block sizes improve burst recovery efficiency but require more delay. Smaller block sizes reduce latency but increase bandwidth usage.

Rate Limiter (On / Off)

The Rate Limiter enables or disables bandwidth control for error correction packets.

This feature helps manage bandwidth usage when error correction is active. While MicroMPX cannot detect your actual available bandwidth, the rate limiter allows you to fine-tune how much bandwidth is used for recovery packets.

Important considerations:

- Turning the Rate Limiter **off** can cause network congestion if recovery packets are sent too aggressively - especially when Overhead is set high.
- Excessive recovery traffic may cause the network to drop packets.
- If error correction is enabled, it is recommended to **leave the Rate Limiter enabled**.

Limit Rate Below

This setting caps the total bandwidth used by the stream (including error correction) below a specified value.

Because error correction packets are generated in bursts at the end of each Size block:

- The Rate Limiter releases packets into the network in a controlled manner.
- This prevents temporary network overload.

If this value is set higher than the network can support:

- The network may become overloaded and begin randomly dropping packets.
- In extreme cases, the rate limiter may discard recovery packets to ensure normal stream packets are delivered.
 - The network itself cannot distinguish between regular audio packets and recovery packets.
 - Severe congestion may lead to dropouts if too many packets are discarded.

For best results, configure this setting based on realistic bandwidth availability and your chosen Size and Overhead parameters.

Proper configuration of **Size**, **Overhead**, **Decoder Delay**, and **Rate Limiting** is essential to achieving reliable performance without unnecessarily increasing bandwidth consumption.

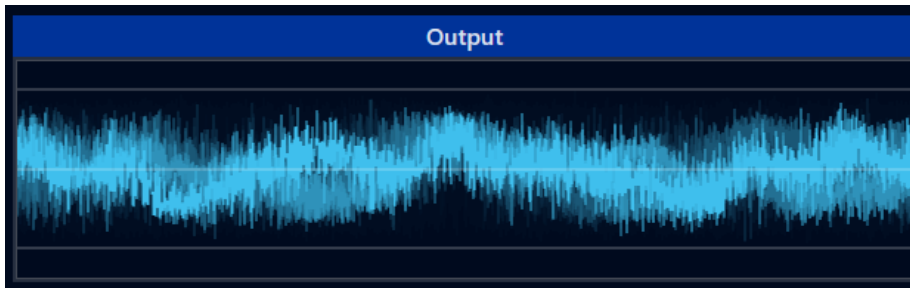

The **Output display** provides a real-time view of your audio levels, including a clip indicator that flashes when signal levels exceed the safe range.

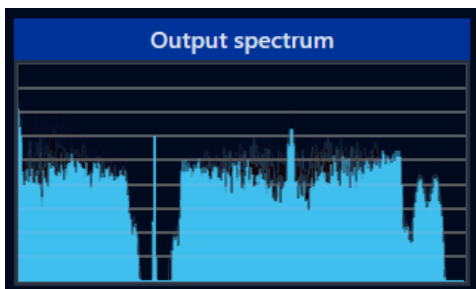

The **Output Spectrum** display provides a view of the FM signal, including L+R, 19kHz stereo pilot L-R, and RDS signals.



The **Unit Status** section on the Dashboard page displays general configuration, system, and network information. It is useful for monitoring details such as uptime, CPU temperature and load, and firmware versions.

USER ACCOUNTS

DEVA[®] BROADCAST Stream Input Security GPS **User accounts** System Account

User accounts

Password protection

Password protection

JSON token

User account setup

| Enabled | Active | User name | New Password | New Password (again) |
|-------------------------------------|-------------------------------------|-----------|----------------------|----------------------|
| <input checked="" type="checkbox"/> | <input checked="" type="checkbox"/> | admin | <input type="text"/> | <input type="text"/> |
| <input checked="" type="checkbox"/> | <input checked="" type="checkbox"/> | user | <input type="text"/> | <input type="text"/> |

Apply changes

User name

Password

Account

Account

Logged in as

admin

DB9410-TX provides you with protected access to the device settings. You can choose between two types of log in.

as Administrator

- It will give you full control over the device's settings;

as User

- that will allow you to just monitor the device, while all the settings remain locked.

In order for the security of DB9410-TX to be enhanced, new username and password could be set from the Security section.

You can also generally disable the password protection option or select JSON token.

SYSTEM

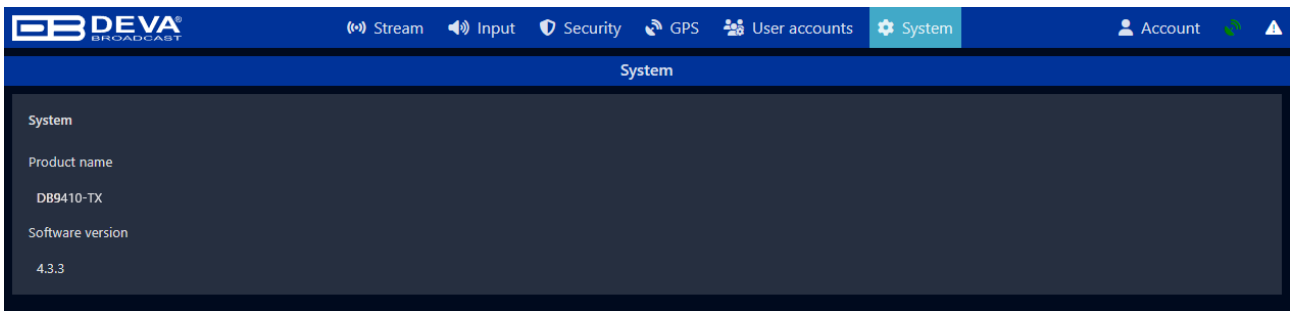

Contains information on the current System status.

ACCOUNT

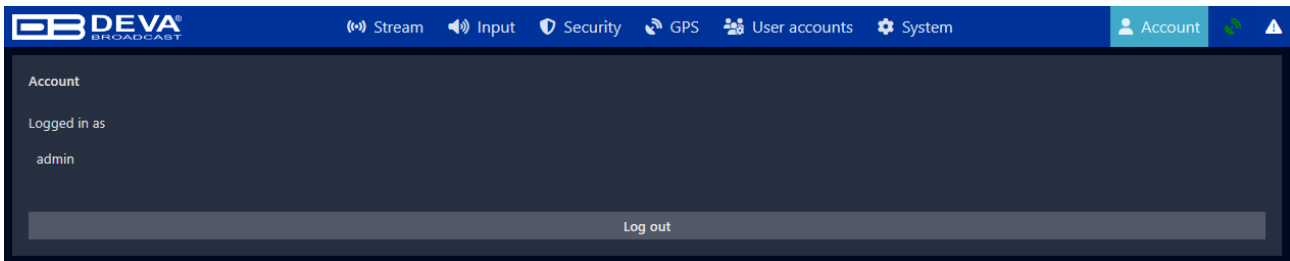

Information on the account with which you are logged-in.

APPENDIX A - Possible problems and solutions

This section describes some issues that you might run into, plus and information on how to solve them.

PEAK CONTROL IS NOT PERFECT

Make sure that the input level and gain on the encoder are set such that peaks in the input signal reach exactly 0 dB (100%) on the waveform display. A warning will be shown if the level is too low. **NOTE** that setting it too high is bad as well, because values above 100% cannot be encoded, so the level must match exactly.

APPENDIX B - RIST URL Syntax and Examples

This documents the URL options for ristsender and ristreceiver by which you can individually customize each RIST connection independently of the global parameters set in the command lines. Note that the binaries support up to ten -o URLs, separated by commas. Note that all the options below apply to the [rist://](#) URL with the exception of “miface”, which applies to inbound multicast packets for ristsender or outbound on rist receiver.

This help text consists of three parts. The default help text you may see with the --helurl command line option, descriptive text for each of the options below it, and then finally, additional examples.

URL HELP OUTPUT

Main help can be accessed via `ristsender --helpurl`

Usage: append to end of individual [rist://](#) url(s) as `?param1=value1&m2=value2...`

Simple, Main and Advanced Profiles

param `buffer=###` – buffer size in milliseconds
param `bandwidth=###` – max bandwidth in Kbps
param `return-bandwidth=###` – max bandwidth for messaging return in Kbps
param `reorder-buffer=###` – reordering buffer size in ms
param `cname=abcde` – arbitrary name for stream for display in logging
param `rtt-min=###` – minimum expected rtt
param `rtt-max=###` – maximum expected rtt
param `verbose-level=#` – Disable -1; Error 3, Warning 4, Notice 5, Info 6, Debug 7, simulation/dry-run 100
param `miface=(device)` – device name (e.g. eth0) for multicast
param `session-timeout=###` – timeout in ms for closing of connection where keep-alive fails

Main and Advanced Profiles

param `aes-type=#` – 128 = AES-128, 256 = AES-256 must have passphrase too
param `secret=abcde` – encryption passphrase
param `virt-dst-port` – destination port inside the GRE header
param `keepalive-interval=###` – interval in ms
param `key-rotation=##` – number of IP packets before a key rotation is triggered
param `congestion-control=#` – mitigation mode: (0=disabled, 1=normal, 2=aggressive)
param `min-retries=##` – min retries count before congestion control kicks in
param `max-retries=##` – max retries count
param `weight=#` – default weight for multi-path load balancing. Use 0 for duplicate paths.
param `stream-id=#` – ID number (even number) for multiplex/demultiplexing steam in peer connector

Advanced Profile

param `compression=1|0` – enable lz4 levels

Usage: append to end of individual [udp://](#) url(s) as `?param1=value1¶m2=value2...`

ADDITIONAL EXPLANATIONS

Below are additional explanations of each of the above parameters:

- `buffer=###` – sets the buffer size in milliseconds. The buffer size will work best at four to seven times the ping time. This allows time for requests for the retransmission of a lost or corrupted packet, and the subsequent retransmission of its replacement. If your stream traverses undersea fiber routes or other types of sometimes unstable or congested routes, you may require an even bigger buffer. This buffer will “delay” the stream by the amount of the buffer, but the stream will arrive without added jitter. We often say that there should be a “tuning period” for a RIST configuration. The log will tell you how many packets were recovered during any connection. We recommend taking a day or two when setting up a connection that you expect to run for long periods of time, monitoring the log, and adjusting the buffer up (or down) little by little, where necessary.
- `bandwidth=###` – sets the maximum bandwidth in Kbps. It is necessary to configure the bandwidth to be higher than the max bandwidth of your stream(s). This is in order to allow room for messaging headroom, plus the re-requested packets. When tuning a connection for the first time, analyze your stream statistics locally at first, then start at 10% higher for a constant bitrate, 100% higher for variable bitrate. Especially for VBR, provide generous “headroom” in your bandwidth. You can always reduce it when configuring and tuning the connection.
- `return-bandwidth=###` – sets the maximum bandwidth in Kbps for just the receiver-to-sender direction. This is an option which may sometimes help avoid congestion insofar as it may limit re-request messages in poor network conditions.
- `reorder-buffer=###` – sets the size for a secondary buffer in which after all re-requested packets have been received, the out-of-order packets are released in the correct order. In most cases there should be no need to adjust this setting, but it may be helpful in conjunction with very long distance/large buffer/poor network conditions.
- `cname=abcde` – provides a canonical name for the media. If multi-plexing more than one stream through a tunnel, this provides a convenient way to identify a particular stream within the log. You should make it standard practice to assign a canonical name whenever multi-plexing. (see also `stream-id`, below).
- `rtt-min=###` – sets the minimum rtt setting in milliseconds. This can help reduce congestion by reducing the number of repeated re-requests in poor network conditions. More importantly, for very long-distance or connections that traverse under-sea cables, it may be important to adjust this setting. If you search for “Global ping Statistics” you will find a number of sites which test and track such times between various city pairs; this data is sometimes helpful for intercontinental connection tuning.
- `rtt-max=###` – sets the maximum rtt setting in milliseconds. See `rtt-min` for a more complete description. In most cases, minimum and maximum should be set to be equal to one another.
- `verbose-level=#` – The verbosity settings match the standard Syslog options. These are self explanatory: -1 for disable. 3 for errors only. 4 adds warnings. 5 adds notices. 6 adds info. 7 for debug mode. 100 allows you to dry-run or simulate the RIST connection.
- `aes-type=#` – specifies the specific encryption. Specify “128” for AES-128 or “256” for AES-256. Remember that you must also specify the pass phrase, and that encryption is not supported for the simple protocol at all.
- `miface=(device)` – sets the adapter for multicast protocol, as in the example `&miface=eth1`. Note that the [rist://](#) URLs must be unicast IP addresses; however, the media stream URLs, as in [udp://xxx.xxx.xxx.xxx](#) may be multicast.

- `session-timeout=###` – terminates the RIST connection after inactivity/lack of keepalive response for the limit (in milliseconds) which you set with this parameter.
- `secret=abcde` – sets the specified passphrase for Main or Advanced profile encryption. Note that simple protocol does not support encryption, and that you must in addition to the “secret” specify the “aes-type” parameter. The rotating keys shall be placed inside the rtp messages, using your passphrase as the pre-shared key. Be sure that the passphrase for sender and receiver match!
- `virt-dst-port` – The port within the GRE tunnel. This has nothing to do with the media port(s). If the GRE is device `/dev/tun11`, having an address of `1.1.1.2`, and the virtual destination port is `10000`, and your media is using port `8193/4`, the operating system will use `1.1.1.2:10000` as the destination from the sender’s point of view, or the inbound on the receiver’s point of view. libRIST will make use of that device/IP/port. As far as your media source and media player are concerned, the media is on ports `8193/4` on their respective interfaces. The media knows nothing of the tunnel.
- `keepalive-interval=###` – time in milliseconds between pings. As is standard practice for GRE tunnels, the keep alive helps ensure the tunnel remains connected and open should no media be traversing it at a given time.
- `key-rotation=##` – sets the key rotation period in milliseconds when aes and a passphrases are specified.
- `congestion-control=#` – libRIST provides built in congestion control, which is important in situations in which a sender drops off the connection, but the receiver still sends re-requests. The three options for this parameter are `0=disabled`, `1=normal` and `2=aggressive`. In general, don’t set the parameter to “aggressive” unless you’ve definitely established that congestion is a problem.
- `min-retries=##` – sets a minimum number of re-requests for a lost packet. Note that setting this too high can lead to congestion. Regardless of this setting, the size of the buffer and the roundtrip time will render too high a minimum value here irrelevant.
- `max-retries=##` – sets a maximum number of re-requests for a lost packet. See “min-retries.”
- `weight=#` – sets the relative share for load balanced connections. The best way to describe this will be to provide an example. The default is five, so in a setup where two paths are given weights of 5 and 10 respectively, the former would receive 1/3 of packets sent, and the latter would receive 2/3.
- `stream-id=#` – sets the encapsulated udp destination port, this must be even. This parameter can be applied to the [rist://](#) url on the sender, and to the [udp://](#) or [rtp://](#) URL on the receiver. The former “assigns” the ID. The latter allows you to specify which multiplexed stream the receiving side will output as a given IP/port output URL. You can therefore have up to ten streams in and ten streams out for a single RIST connection. Each individual stream must have a unique ID and its output shall then handle the ID accordingly. It is possible to send multiple streams through a GRE tunnel and only output selected streams at the receiving side, though that wastes the bandwidth. Such a routing scenario, however, allows for a sending side to send all streams to multiple receivers via one command line, putting the “onus” on the receivers to sort out their desired streams.
- `compression=1|0` – utilizes liblz4 to compress all traffic in the GRE tunnel.

EXAMPLES

| Code | Meaning |
|---|---|
| <pre>ristsender -p 1 -e 128 -s blarg -i udp://@192.168.1.6:11111 -o rist://123.124.125.126:8200?buffer=675&rtt-min=75&bandwidth=3036,rist://204.222.122.12:8200?buffer=140&rtt-min=20&bandwidth=2560</pre> | <p>Main profile to senders with very different network paths. Note the support for up to ten -o URLs when separated by commas. In this case we assume a ping time of 75ms to the first destination and 20ms to the second. We have set the bandwidths for seven times the rtt, and reduced the maximum bandwidth necessary for the second destination.</p> |
| <pre>ristsender -p 1 -e 128 -i udp://225.0.0.4:1971?miface=eth1 -o rist://@162.247.59.66:8200?cname=listener01&buffer=700&bandwidth=2048&keepalive-interval=25000&session-timeout=60000&secret=pwd01,rist://@162.247.59.66:8202?cname=listener02&buffer=700&bandwidth=2048&keepalive-interval=25000;secret=pwd02&session-timeout=60000,rist://@162.247.59.66:8204?cname=listener03&buffer=350&bandwidth=2048&keepalive-interval=25000&session-timeout=60000;secret=pwd03</pre> | <p>Main profile, multicast media input, three receivers with AES-128 encryption but with separate passphrases and buffer values. In each case the sender listens for the receiver to contact it. Session keepalives and timeouts are set so that if a listener drops off, another, knowing the proper port and passphrase, can take its place.</p> |
| <pre>ristsender -p 1 -e 128 -s blarg -i udp://225.0.0.4:25000?miface=eth1&cname=stream01&stream-id=2,udp://225.0.0.5:26000?miface=eth1&cname=stream02&stream-id=4,udp://225.0.0.6:28000?miface=eth1&cname=stream03&stream-id=6 -o rist://111.222.27.13:8204?buffer=350&bandwidth=5120</pre> | <p>Multiplex example, showing three incoming multicast streams, each given a unique ID and canonical name (the latter helps distinguish them in the log). The three are sent to a single receiver via main profile with AES-128 encryption. Note that the buffer is not increased for three streams, but the bitrate is. At the other end, the receiver will distinguish between the three using the stream-ids, which it must know beforehand.</p> |

APPENDIX C - Recovery mode

Recovery mode is designed to fix, update, or reinstall the DB9410's core operating system when the main firmware is corrupted, in need of firmware update or malfunctioning (a "bricked" state). It allows re-flashing the device's firmware to restore normal operation.

In this mode, the device cannot perform normal tasks, but instead acts as a receiver for new, clean firmware files.

IMPORTANT: Using recovery mode to reinstall firmware may wipe all user settings and data from the device.

HOW TO ENTER RECOVERY MODE?

1. Locate the RESET button on Rear panel;

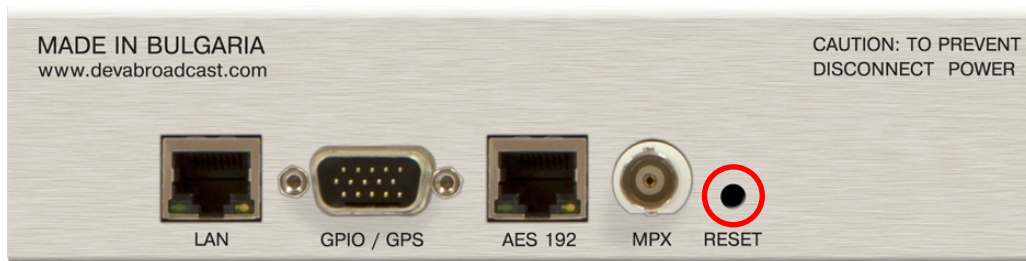

2. Press and hold the RESET button;
3. Keep pressing the RESET button and hold until the POWER and MEMORY LEDs blink 3 times alternately, then stop. This indicates that the device has entered RECOVERY mode;
4. Release the RESET button;
5. Allow 1 minute for the device to boot;
6. Open the devices RECOVERY WEB interface. For this purpose, you will need to know the DB94's IP address. If you are not aware of it, please use the DEVA Ethernet Setup Tool ([see "DEVA Ethernet Setup Tool" on page 24](#)).
7. A successful log-in will look as follows:

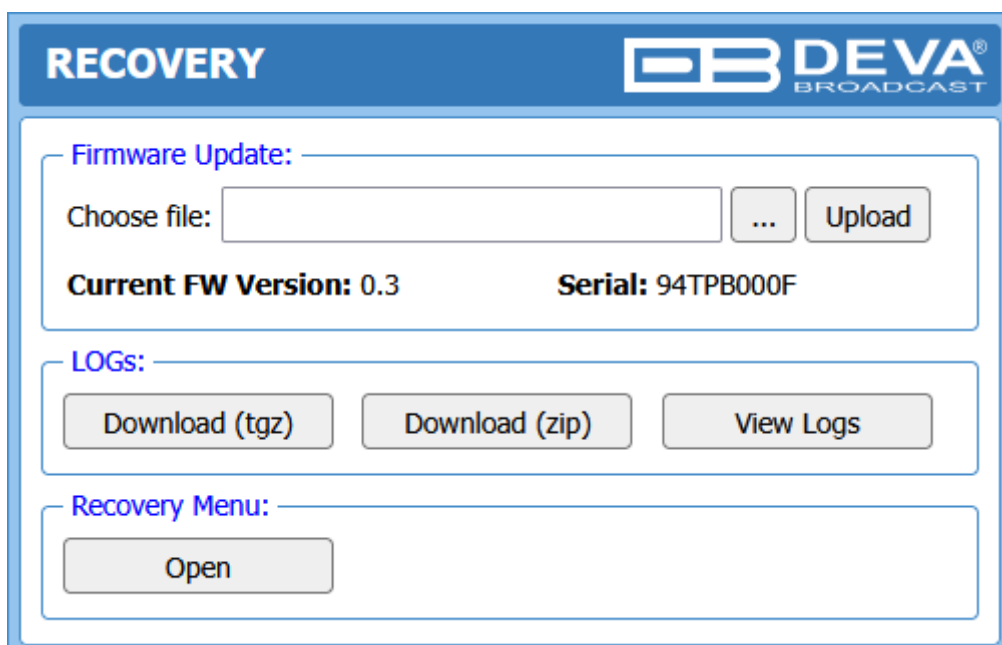

FIRMWARE UPDATE

The firmware update section allows users to verify the current firmware version, device serial number and installing updates.

1. In section Firmware Update press [Choose file];
2. Select the **.upgbox** file to be used and press [Open]. The latest firmware is available for downloading at <http://www.devabroadcast.com/downloads>

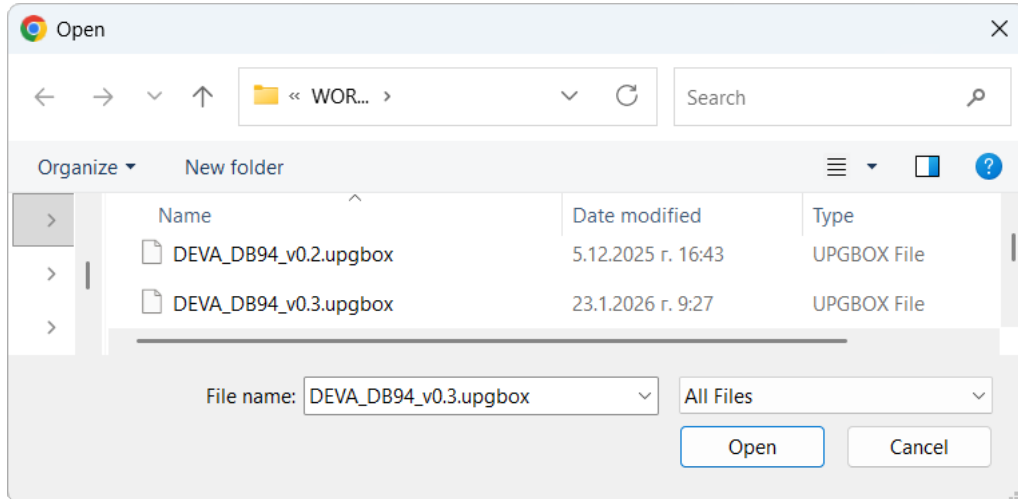

3. The following message indicating start of the process will appear:

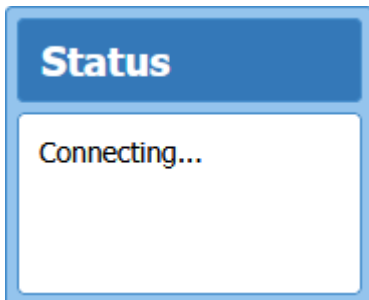

4. A message indicating "Copying of the system" will appear:

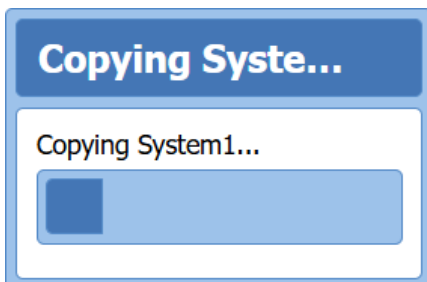

5. Once system file copying finishes, press [OK] when prompted to initiate the final installation phase:

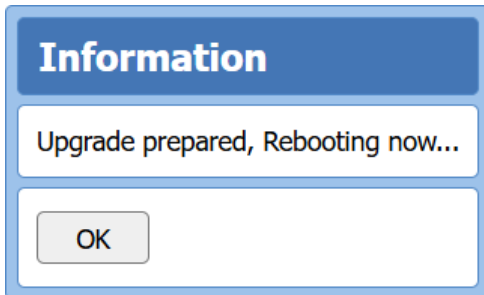

6. Upon Rebooting, the device will loose it's network connection and you will need to reconnect to the WEB Interface manually.

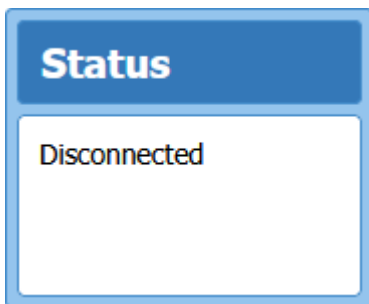

7. The IP address of the device will be changed. You will need to use DEVA Ethernet Setup Tool ([see "DEVA Ethernet Setup Tool" on page 24](#)) to find the newly assigned IP.

LOGs

The Recovery mode is also used for accessing, viewing, or downloading of the system logs.

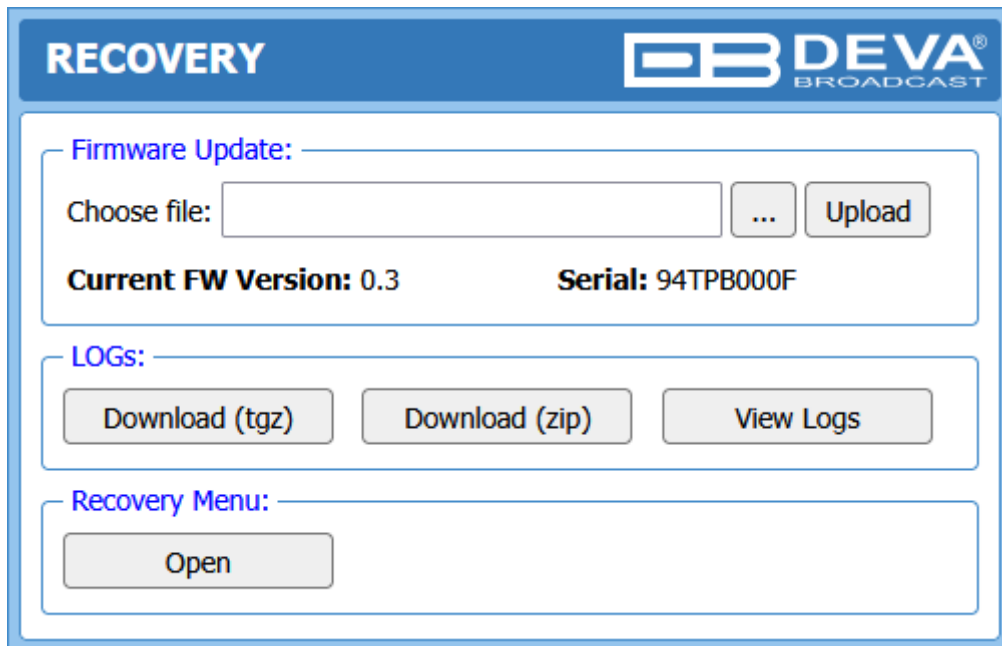

The screenshot shows the 'RECOVERY' interface with the DEVA BROADCAST logo. It features three main sections: 'Firmware Update' with a file selection field and an 'Upload' button; 'LOGs' with buttons for 'Download (tgz)', 'Download (zip)', and 'View Logs'; and 'Recovery Menu' with an 'Open' button. The current firmware version is 0.3 and the serial number is 94TPB000F.

RECOVERY MENU

Recovery menu is a built-in troubleshooting environment used to factory reset, reboot or update the firmware.

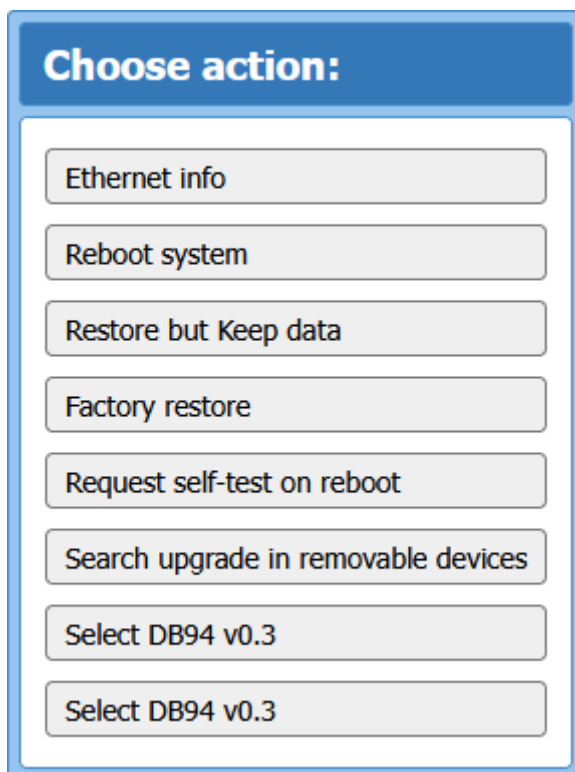

The screenshot shows the 'Choose action:' menu with the following options: Ethernet info, Reboot system, Restore but Keep data, Factory restore, Request self-test on reboot, Search upgrade in removable devices, Select DB94 v0.3, and another Select DB94 v0.3 option.

WARRANTY TERMS AND CONDITIONS

I. TERMS OF SALE: DEVA Broadcast Ltd. products are sold with an understanding of “full satisfaction”; that is, full credit or refund will be issued for products sold as new if returned to the point of purchase within 30 days following their receipt, provided that they are returned complete and in an “as received” condition.

II. CONDITIONS OF WARRANTY: The following terms apply unless amended in writing by DEVA Broadcast Ltd.

A. The Warranty Registration Card must be completed and returned to DEVA Broadcast Ltd. within 10 days of delivery. Product registration can also be done digitally at <https://www.devabroadcast.com/members/product-registration>, after registering on our website, within 10 days of delivery.

B. This Warranty applies only to products sold “as new.” It is extended only to the original end-user and may not be transferred or assigned without prior written approval by DEVA Broadcast Ltd.

C. This Warranty does not apply to damage caused by improper mains settings and/or power supply.

D. This Warranty does not apply to damage caused by misuse, abuse, accident or neglect. This Warranty is voided by unauthorized attempts at repair or modification, or if the serial identification label has been removed or altered.

III. TERMS OF WARRANTY: DEVA Broadcast Ltd. products are warranted to be free from defects in materials and workmanship.

A. Any discrepancies noted within TWO YEARS of the date of purchase will be repaired free of charge, or the equipment will be replaced with a new or remanufactured product at DEVA Broadcast Ltd. option.

B. Parts and labor for factory repair required after the two-year Warranty period will be billed at prevailing prices and rates.

IV. RETURNING GOODS FOR FACTORY REPAIR:

A. Equipment will not be accepted for Warranty or other repair without a Return Material Authorization (RMA) number issued by DEVA Broadcast Ltd. prior to its return. An RMA number may be obtained by placing an RMA request at <https://www.devabroadcast.com/rma>. The number should be prominently marked on the outside of the shipping carton.

B. Equipment must be shipped prepaid to DEVA Broadcast Ltd. Damage sustained as a result of improper packing for return to the factory is not covered under terms of the Warranty and may occasion additional charges.

V. UPDATES TO THE TERMS OF SERVICE:

For the most up-to-date, valid, and accurate terms, conditions, and product documentation, please visit the official DEVA Broadcast Ltd. website downloads section at <https://www.devabroadcast.com/downloads/deva-documents>. Printed documents may not reflect recent amendments. Reviewing the current online versions ensures you have the latest information.



PRODUCT REGISTRATION CARD

- All fields are required, or warranty registration is invalid and void

Your Company Name _____

Contact _____

Address Line 1 _____

Address Line 2 _____

City _____

State/Province _____ ZIP/Postal Code _____

Country _____

E-mail _____ Phone _____ Fax _____

Which DEVA Broadcast Ltd. product did you purchase? _____

Product Serial # _____

Purchase date ____ / ____ / ____

Installation date ____ / ____ / ____

Your signature*

*Signing this warranty registration form you are stating that all the information provided to DEVA Broadcast Ltd. are truth and correct. DEVA Broadcast Ltd. declines any responsibility for the provided information that could result in an immediate loss of warranty for the above specified product(s).

Privacy statement: DEVA Broadcast Ltd. will not share the personal information you provide on this card with any other parties.